

A12WC

1/12-SCALE ELECTRIC ON-ROAD CAR

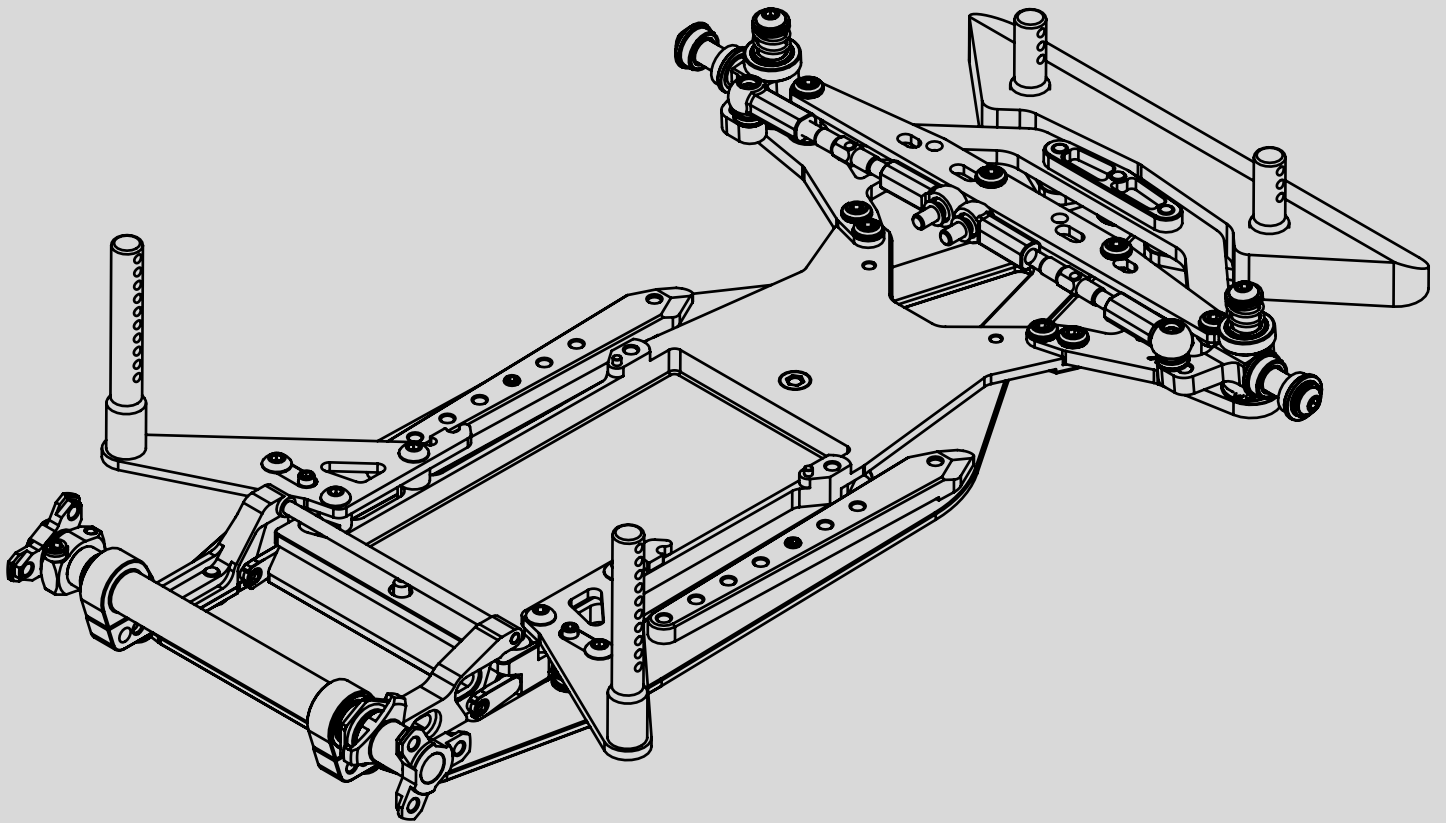

INSTRUCTION MANUAL

INTRODUCTION

Congratulations on purchasing your Awesomatix car!
The A12WC car was produced by UAB Awesomatix company.

BEFORE YOU START

The A12WC car is a high-quality, innovative 1/12-scale on-road car and should only be built by those with previous experience of building R/C model racing cars.

This is not a toy and is not intended for use by children without the direct supervision of a responsible, knowledgeable adult. Please read the instruction manual carefully and fully understand it before beginning assembly. If you encounter any problems or have any questions, please do not hesitate to contact the Awesomatix team at support@awesomatix.com.

Ensure that you are happy with your kit purchase and are committed to use of it prior to beginning the assembly of your A12WC. Your car cannot be returned to UAB Awesomatix for a refund or exchange once it has been fully or partially assembled.

This kit is a radio controlled model racing product and could cause personal injury or harm if not used as intended. The A12WC car is designed for use on r/c car race tracks; it should not be used in areas primarily intended for use by the general public. UAB Awesomatix accept no responsibility for any injury caused by making or using this product.

Due to our policy of continuous product development, the exact specifications of the kit may vary. UAB Awesomatix reserve all rights to modify or change product specifications without prior notice. All rights reserved.

ASSEMBLY NOTES

You can find useful tips for assembly of the A12WC and an editable setup sheet on the Internet website:
<http://site.petitrc.com/reglages/awesomatix/setupa12/>

GENERAL PRECAUTIONS

- Many of the items in this kit are small enough to be accidentally swallowed and are therefore potential choking hazards, making them potentially fatal. Please ensure that when assembling the kit you do so out of the reach of small/young children.
- Take care when building, as some parts may have sharp edges.
- Please read this manual carefully to understand which ancillary items (tools, electrics, electronics etc) are used with this kit. Awesomatix Innovations accept no responsibility for the operation of any such ancillary items.
- Exercise care when using tools and sharp instruments.
- Follow the operating instructions for the radio equipment at all times.
- Never touch rotating parts of the car as this may cause injury.
- Keep the wheels of the model off the ground when checking the operation of the radio equipment.
- To prevent any serious personal injury and/or damage to property, be responsible when operating all remote controlled models.
- The model car is not intended for use on roads or areas where its operation can conflict with or disrupt pedestrian or vehicular traffic.
- Do not run your car in poor light or if it goes out of sight. Any impairment to your vision may result in damage to your car or, worse, injury to others or their property.
- As a radio controlled device, your car is subject to radio interference from things beyond your control. Any such interference may cause a loss of control of your car so please consider this possibility at all times.
- When not using RC model, always disconnect and remove battery.
- Insulate any exposed electrical wiring to prevent dangerous short circuits. Take maximum care in wiring, connecting and insulating cables. Make sure cables are always connected securely. Check connectors for if they become loose and if so reconnect them securely. Never use R/C models with damaged wires. A damaged wire is extremely dangerous and can cause short-circuits resulting in fire.

EQUIPMENT RECOMMENDED (NOT INCLUDED)

- Radio Transmitter
- Radio Receiver
- Electronic Speed Control
- Steering Servo
- Servo Saver
- Electric Motor
- Pinion Gear (64 or 48 Pitch)
- Spur Gear (64 or 48 Pitch)
- 1S Li-Po Battery
- 1/12 scale Body Shell
- 1/12 scale Wheels and Tires

TOOLS RECOMMENDED (NOT INCLUDED)

- 1.5mm, 2.0mm, 3.0mm Hex Drivers
- 12mm Wrench
- Sewing Needle or Sharp Pin
- Callipers
- Hobby Knife
- Ride Height Gauge
- Thin CA Glue
- Thread Lock
- Double Side Tape
- Silicone Oil for Dampers
- Joint Grease

STEP 1

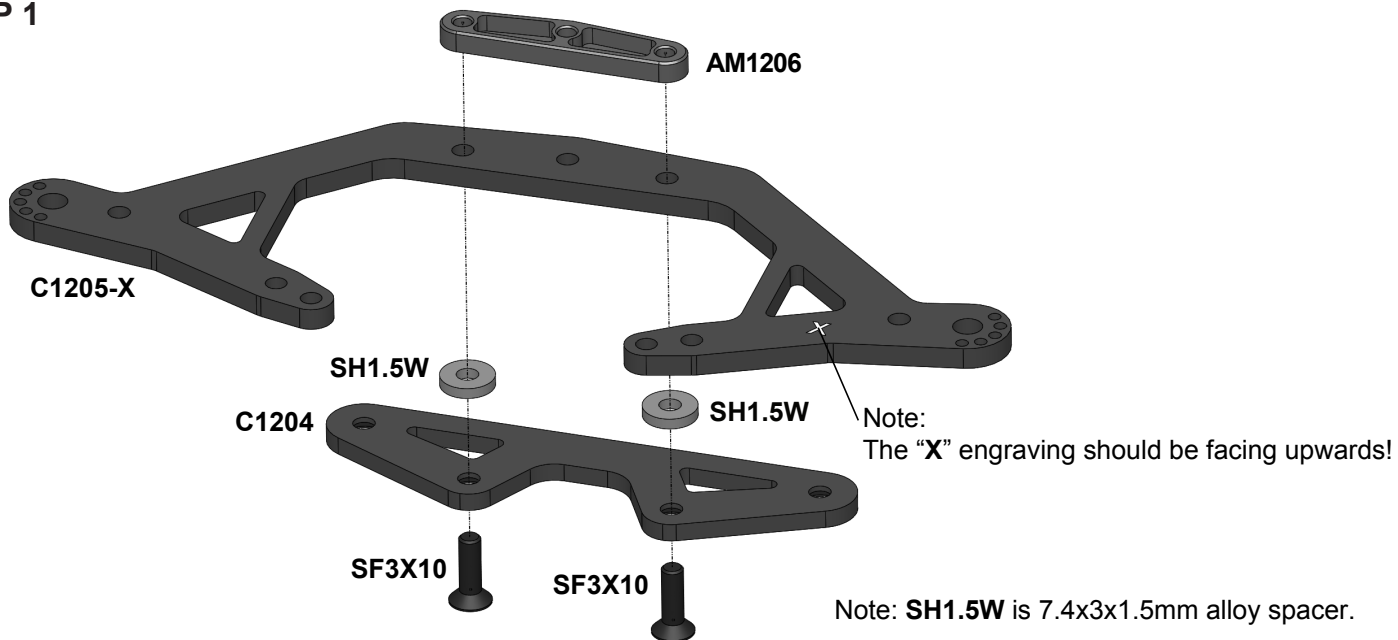

STEP 2

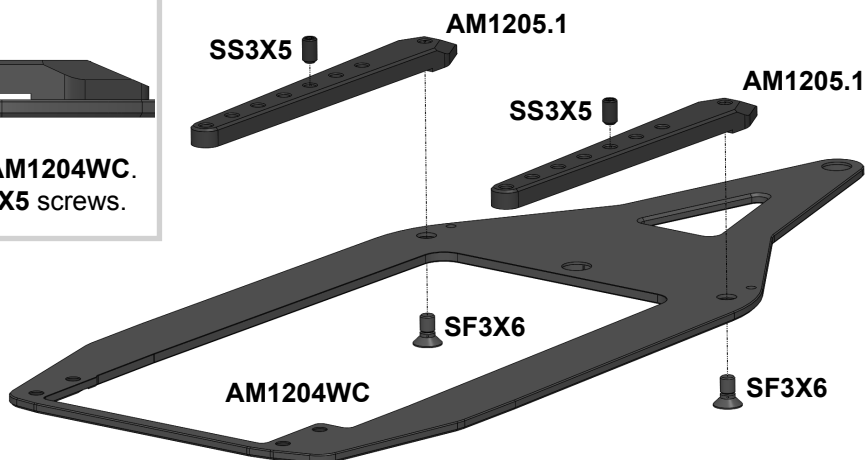
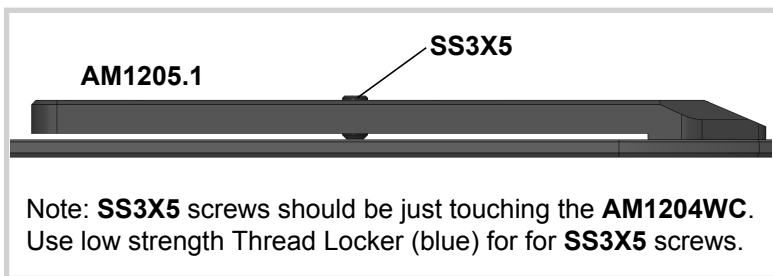

STEP 3

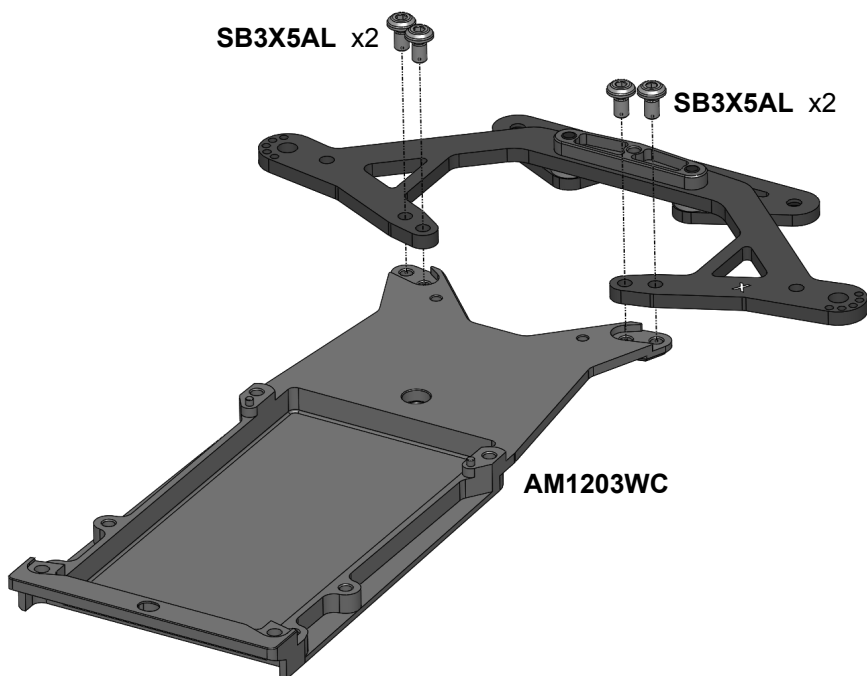

STEP 4

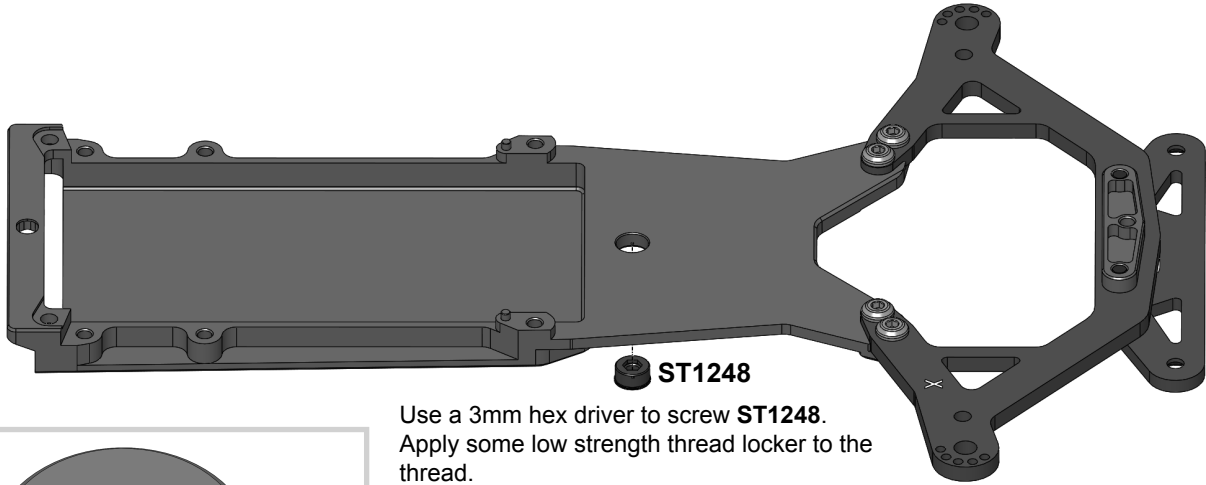

ST1248

Use a 3mm hex driver to screw **ST1248**.
Apply some low strength thread locker to the thread.

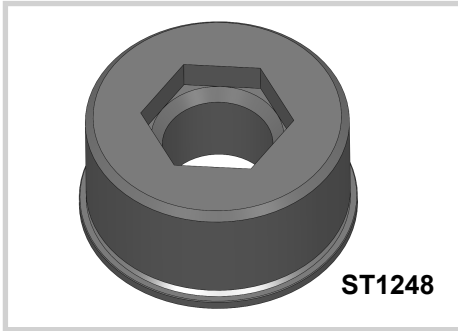

ST1248

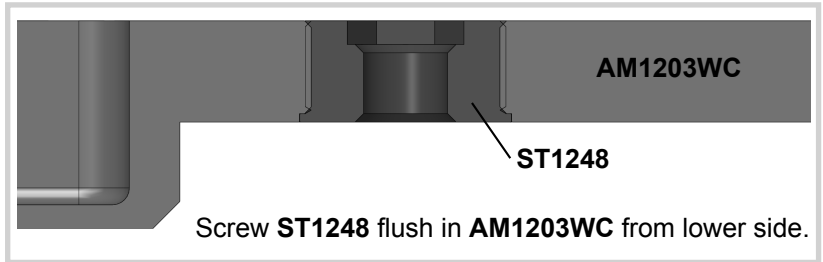

AM1203WC

ST1248

Screw **ST1248** flush in **AM1203WC** from lower side.

STEP 5

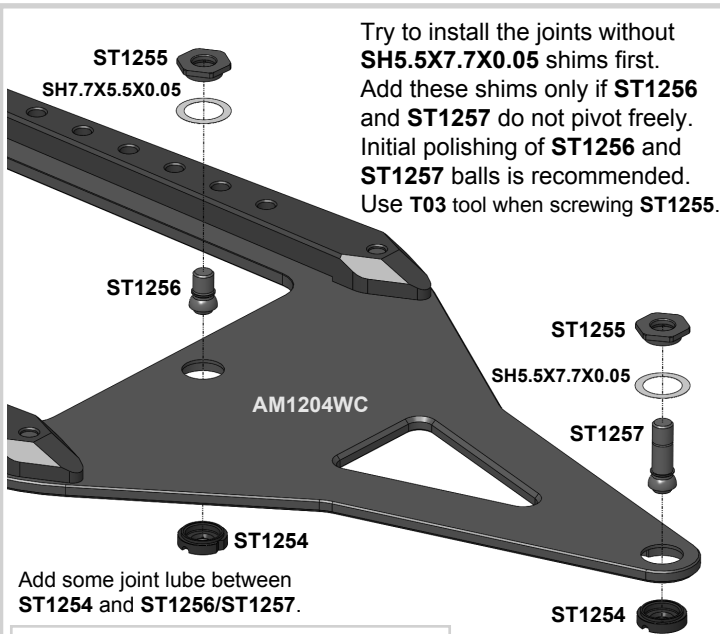

Try to install the joints without **SH5.5X7.7X0.05** shims first. Add these shims only if **ST1256** and **ST1257** do not pivot freely. Initial polishing of **ST1256** and **ST1257** balls is recommended. Use **T03** tool when screwing **ST1255**.

Add some joint lube between **ST1254** and **ST1256/ST1257**.

TIP / Recommendation to use:
MAX-01-002 - MXLR Driveshaft & Gears Oil

Note: The kit's rollcenter set is **LRC** (Low Roll Center) set. Optional rollcenter sets are available (not kit included):
ELRC - Extra Low Roll Center set (-1mm lower rollcenter)
HRC - High Roll Center set (+1mm higher rollcenter)
EHRC - Extra High Roll Center set (+2,8mm higher rollcenter)

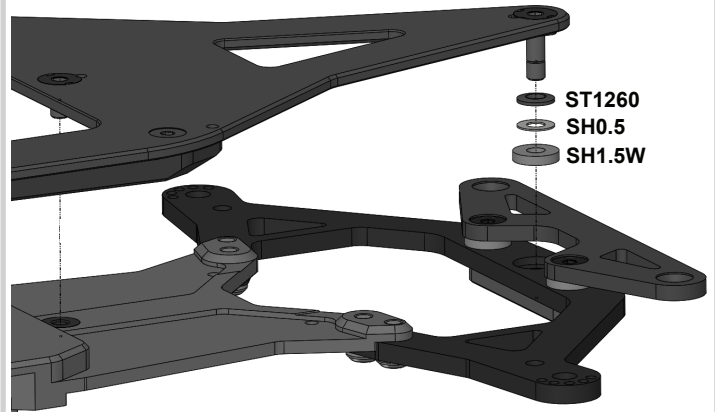

ST1260
SH0.5
SH1.5W

Use a 2mm hex driver to screw **ST1256** and **ST1257**.

After assembly make sure that **AM1203WC** pivots freely relative to **AM1204WC**.

Rear ball joint

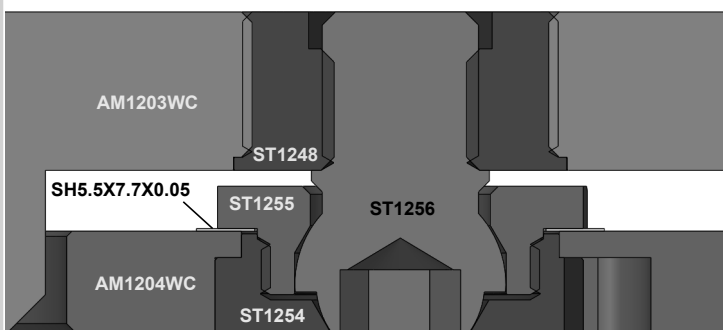

SH5.5X7.7X0.05 shim can be installed to adjust the vertical free play in the joint.

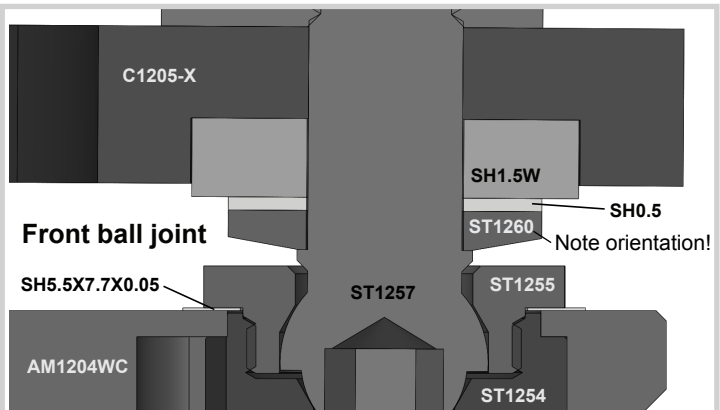

Front ball joint

Note orientation!

SH5.5X7.7X0.05 shim can be installed to adjust the vertical free play in the joint.

STEP 6

Note: Add a bit of silicone oil into groove of **ST1202**.



Note: Lubricate **OR153V** via silicone oil. Stretch **OR153V** via fingers and put it on **ST1202** (to avoid the damage of o-ring please don't use a sharp edged tool for this!).



STEP 7

Note: Add ~0,3 g of 50 000...100 000 cst silicone oil into cavity of **ST1204** damper case. We recommend 100 000 cst silicone oil as the base setup. Keep **ST1204** upright for several minutes until all oil reaches the bottom of the cavity.

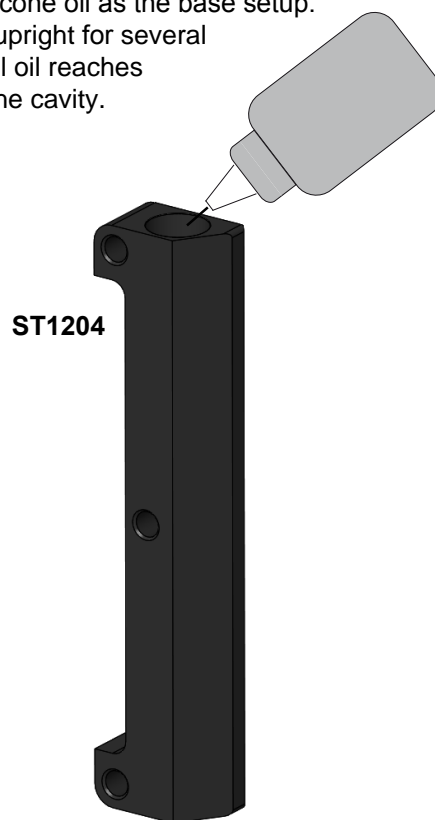

STEP 8

Note: Insert **ST1202** damper rotor into **ST1204** damper case slowly. After the lower face of the **ST1202** reaches the oil in the bottom of the cavity, the **ST1202** will need an additional force to be pushed fully into the proper position. We recommend using a rubber band or **OR230** o-ring as shown in the picture. The oil will start to come up towards the top of the cavity of the **ST1204** as the **ST1202** is pushed further into that cavity by the o-ring. When the **OR153V** o-ring and the **ST1204** damper are close to flush (almost fully inserted), please use a sewing needle or a sharp pin along the recess of the **ST1202** to move the o-ring out of position and allow more oil to be pushed out from the **ST1204** case. Using this needle or pin will allow the **ST1202** to be fully seated and sit perfectly flush with the **ST1204** damper case.

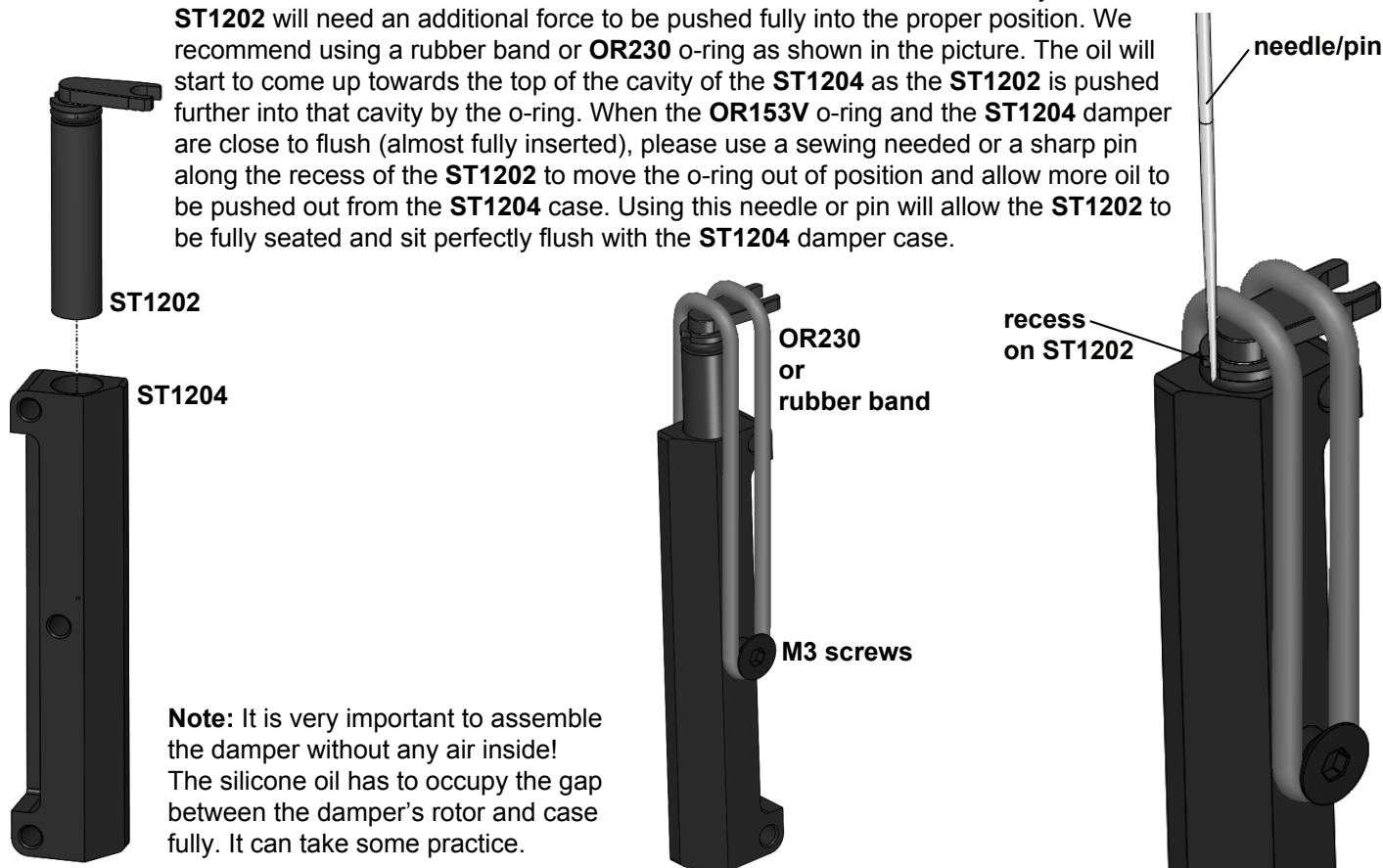

Note: It is very important to assemble the damper without any air inside! The silicone oil has to occupy the gap between the damper's rotor and case fully. It can take some practice.

STEP 9

Repeat the STEPS 5,6,7 for other side of **ST1204** and check that both **ST1202** rotors reached the desirable position (flush with the **ST1204** face)

Note: These faces of **ST1204** and **ST1202** should coincide.

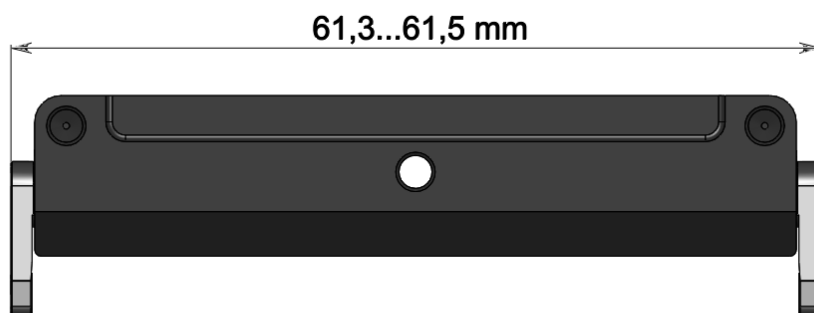
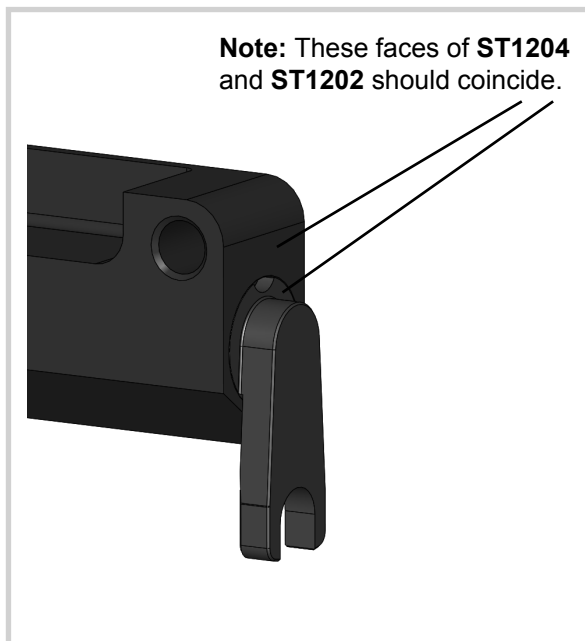

STEP 10

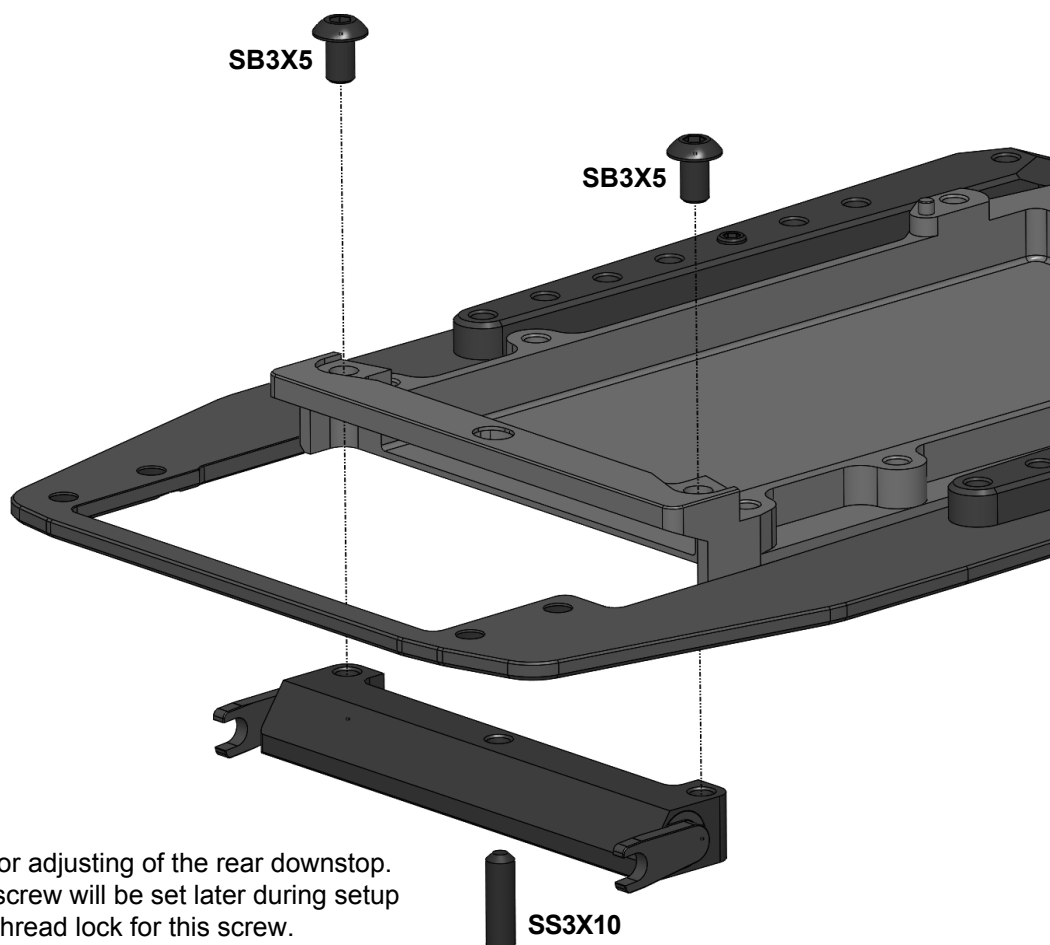

Note: **SS3X10** set screw is used for adjusting of the rear downstop. An exact position of this **SS3X10** screw will be set later during setup of the car. Please use blue "soft" thread lock for this screw.

STEP 11



STEP 12

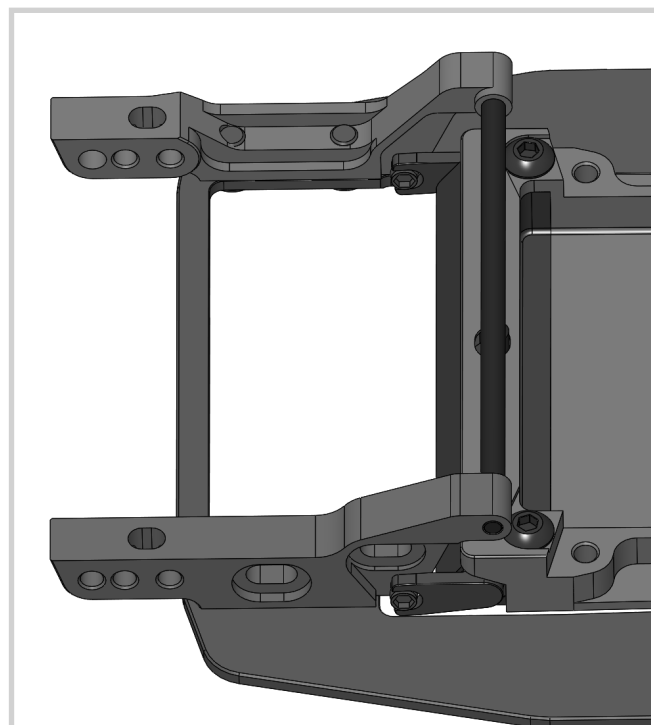
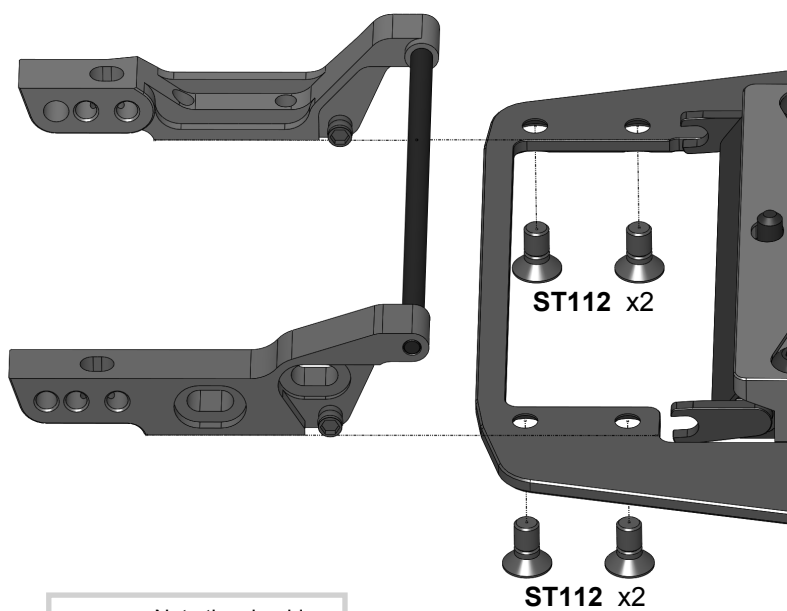

STEP 13

Note: Assortment of **SH** shims is used for setting of the desired Rear Ride Height - **RRH**.

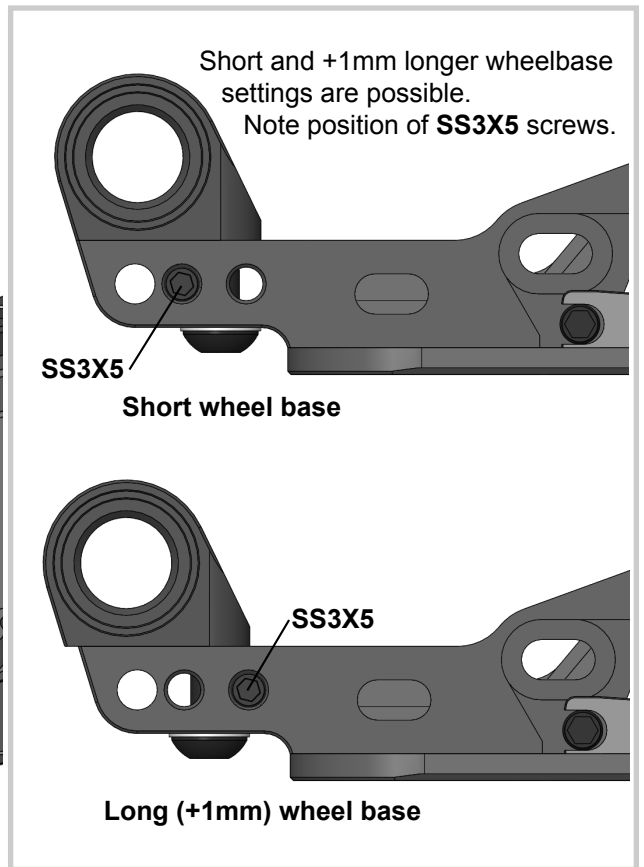
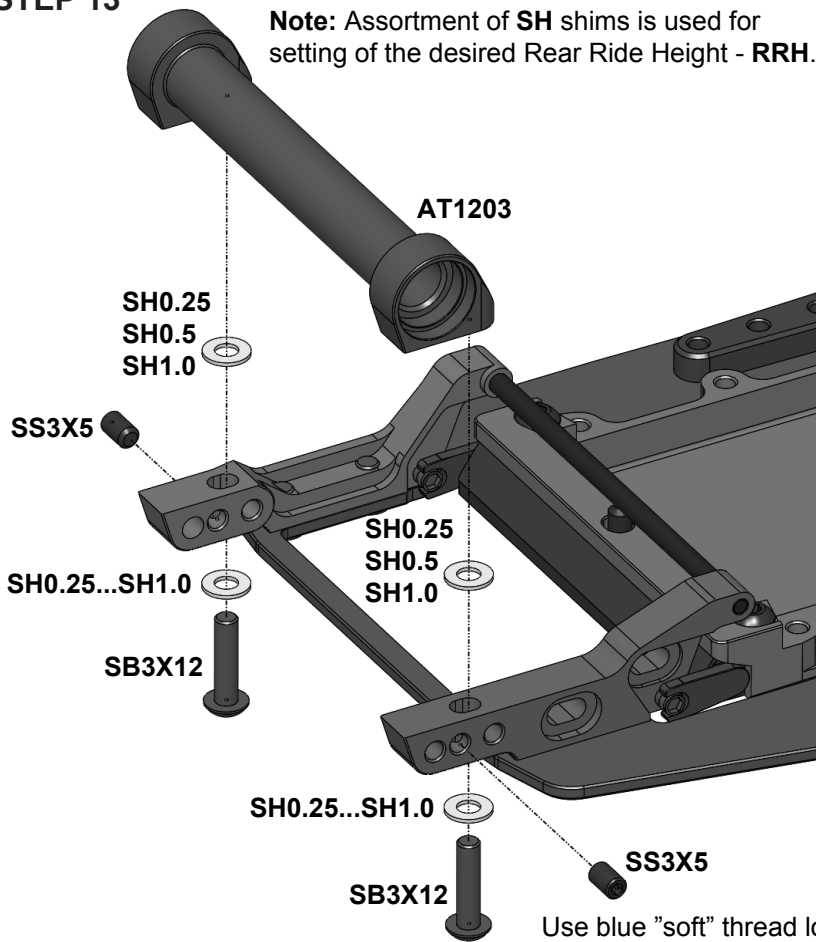

Use blue "soft" thread lock for **SS3X5** screws!

STEP 14

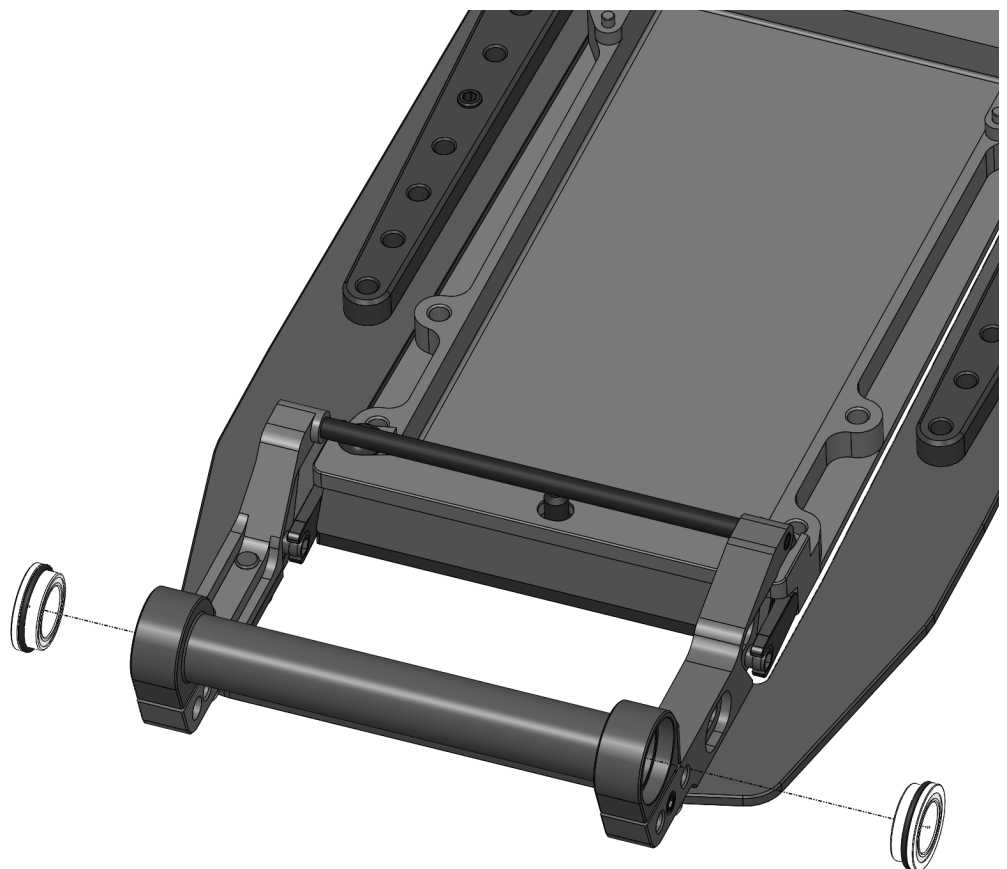

Press both **B168ZZ** bearings into **AT1203** rear beam.

STEP 15

Note: **ST1208-C4AL** steering block posts provide 4 deg caster.
 Optional **ST1208-C5** posts provide 5 deg caster.
 Optional **ST1208-C2** posts provide 2 deg caster.
 Optional **ST1208-C6** posts provide 6 deg caster.

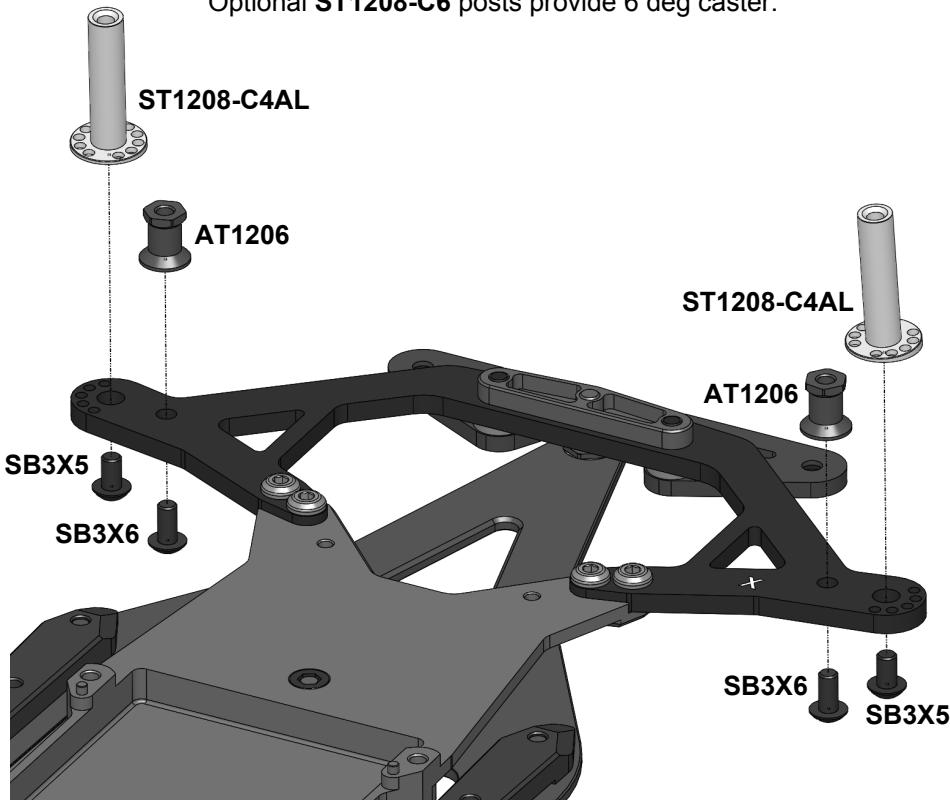

Alignment of the appropriate holes of **ST1208-C4AL** and **C1205-X** for camber settings.

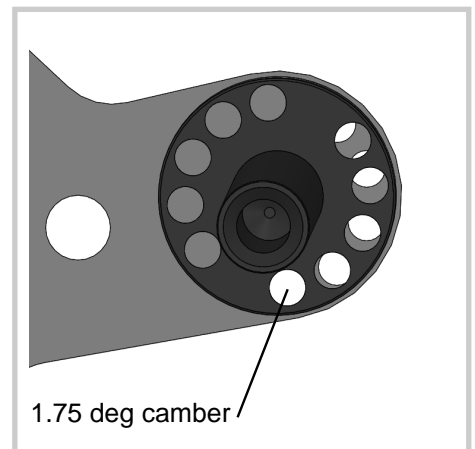
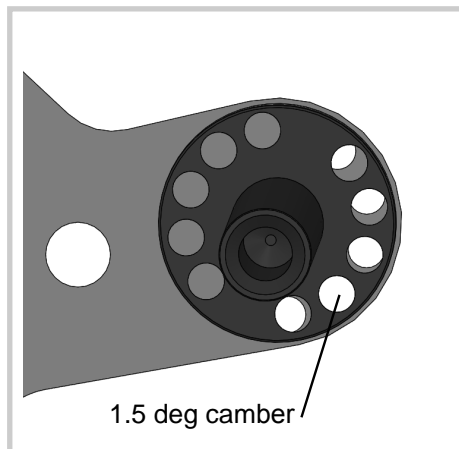
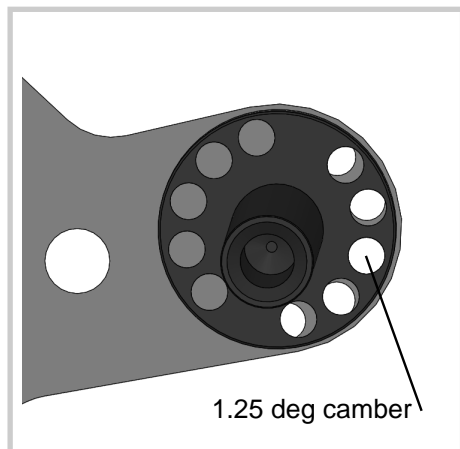
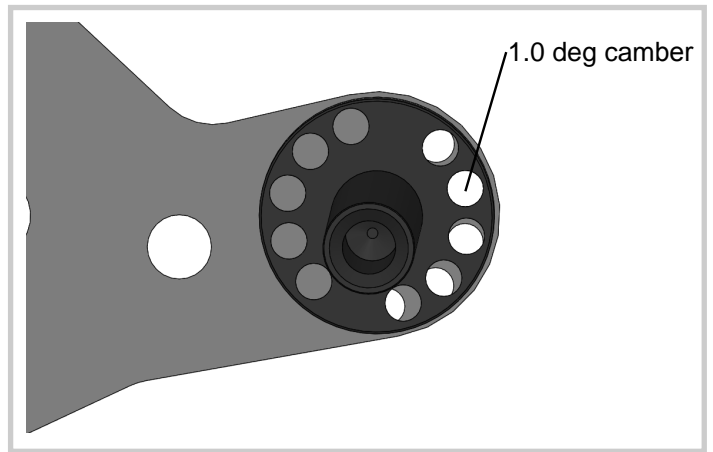
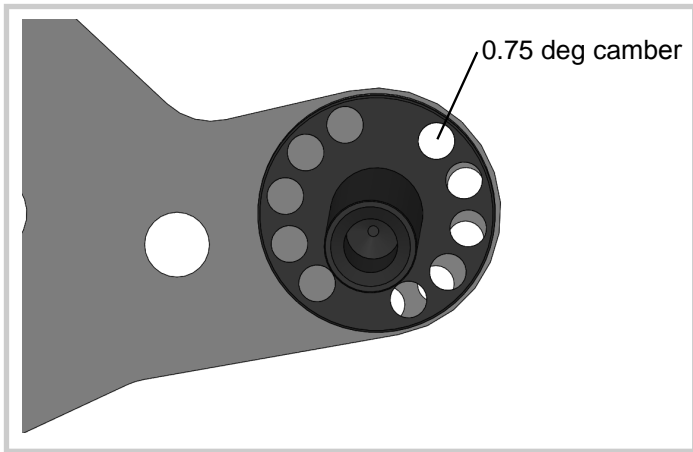

STEP 16

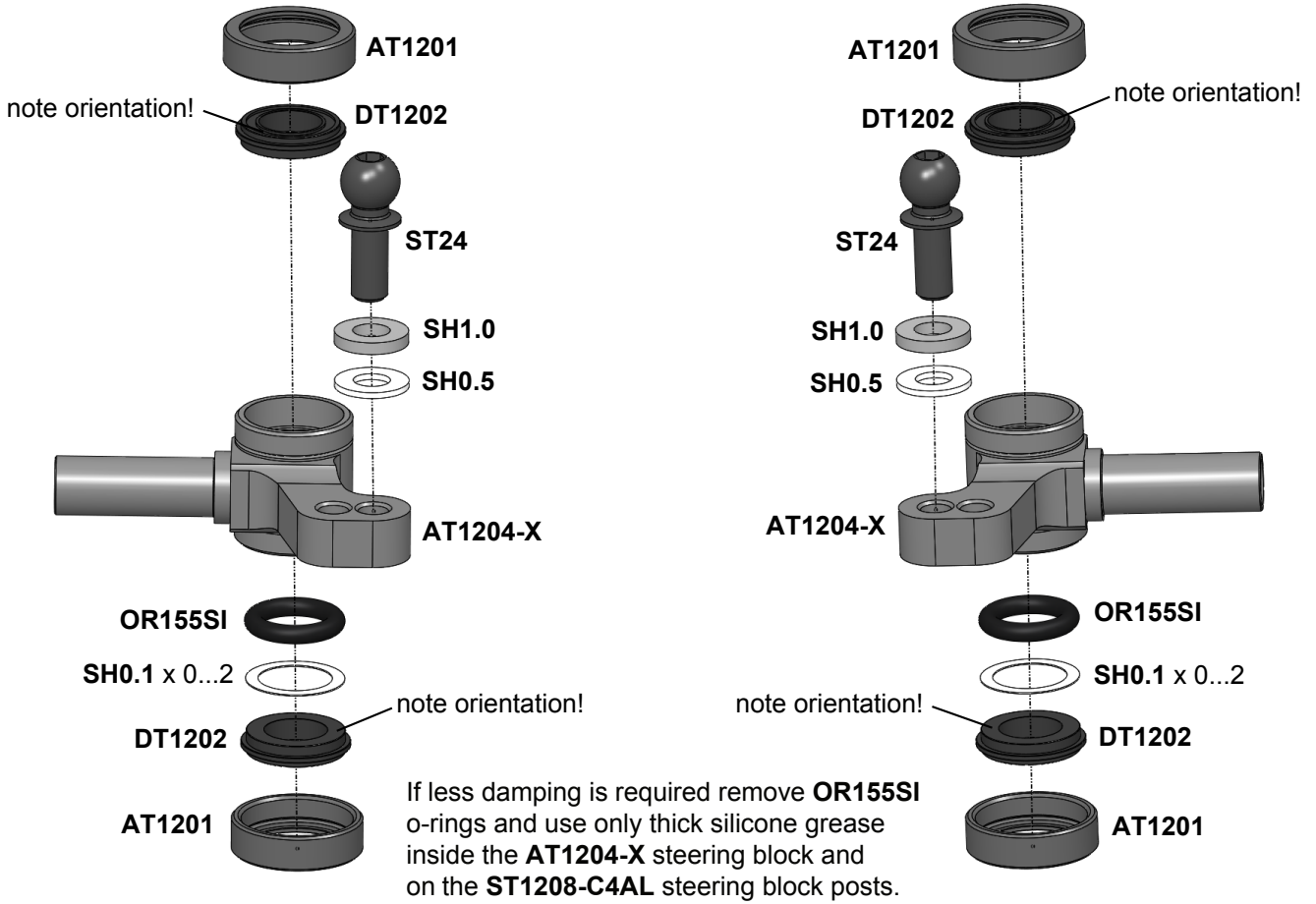

STEP 17

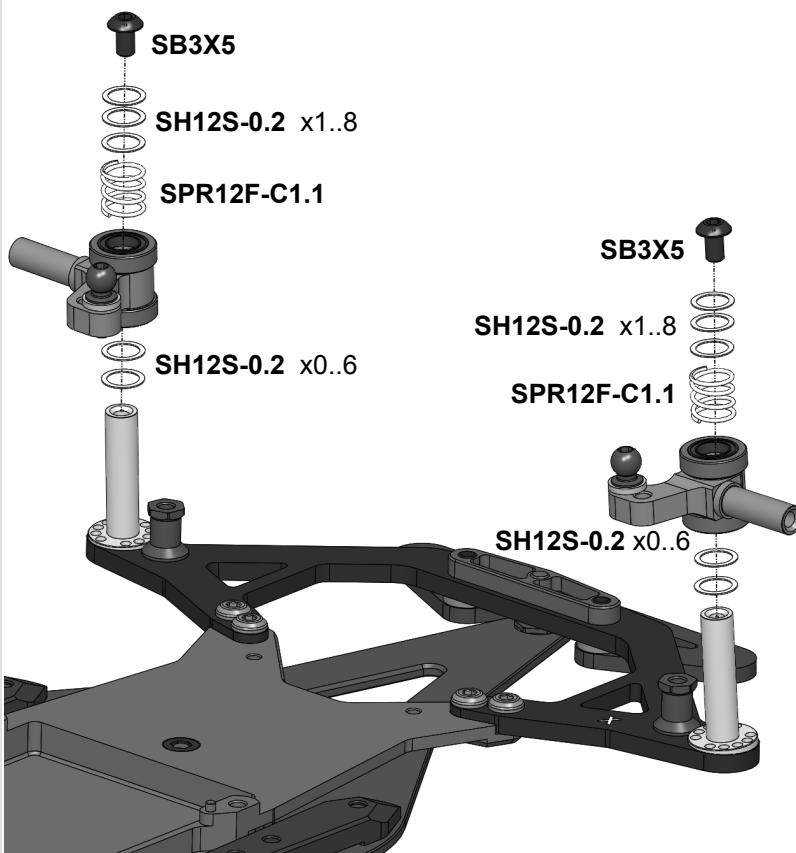

Attention! When installing **SH12S0.2** shims above the spring, make sure all shims surround **ST1208-C4AL** but are not in the gap between **ST1208-C4AL** top face and **SB3X5** screw head.

Top **SH12S-0.2** shims are used to set the front ride height.

Put the desirable silicone grease into this cavity.

Bottom **SH12S0.2** shims are used to set the front droop.

SH12S-0.2 0.2mm thickness shims are used to set the front ride height and the front droop.

STEP 18

Installation of the SANWA SRG servo.

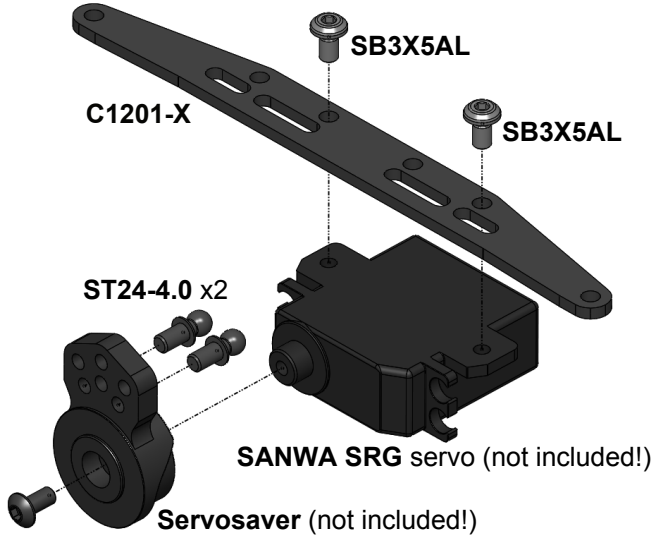

Installation of the standard mini servo.

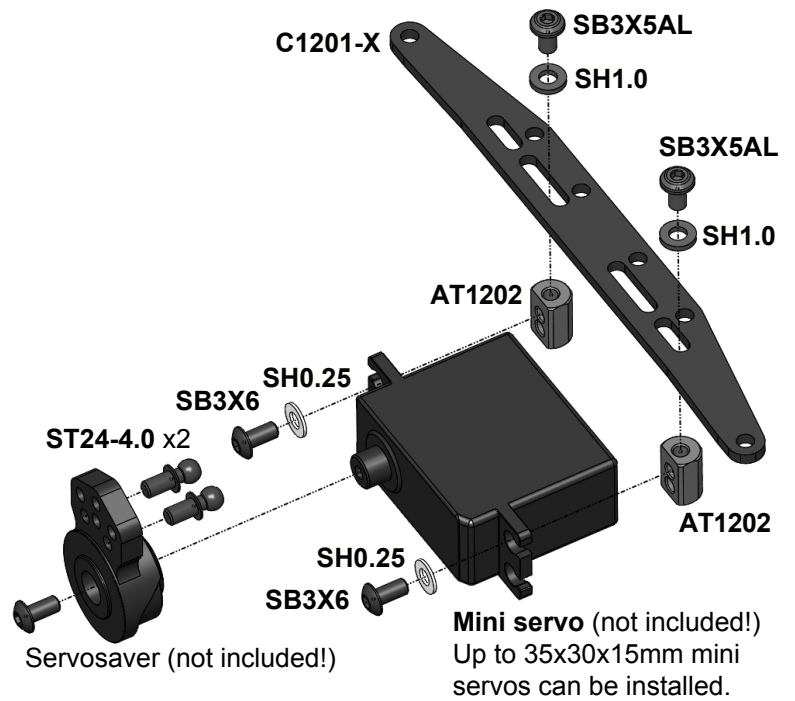

Note: ST24-4.0 are 4.0mm ball studs. ST24-4.0 fit P1213 4.0mm ball cups.

STEP 19

Installation of the SANWA SRG servo.

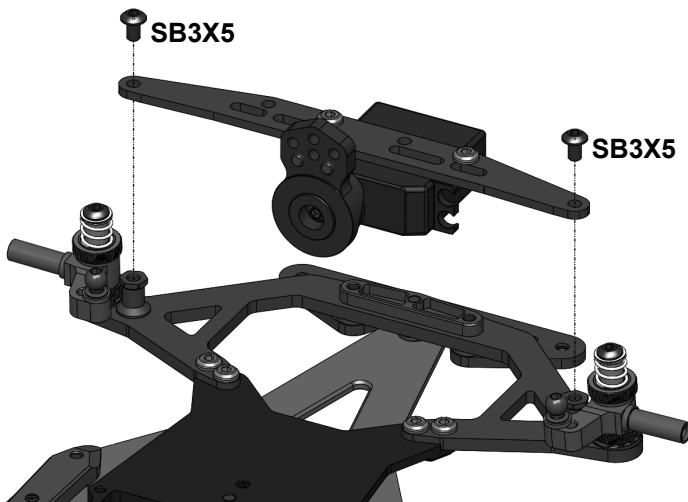

Installation of the 15mm thick mini servo.

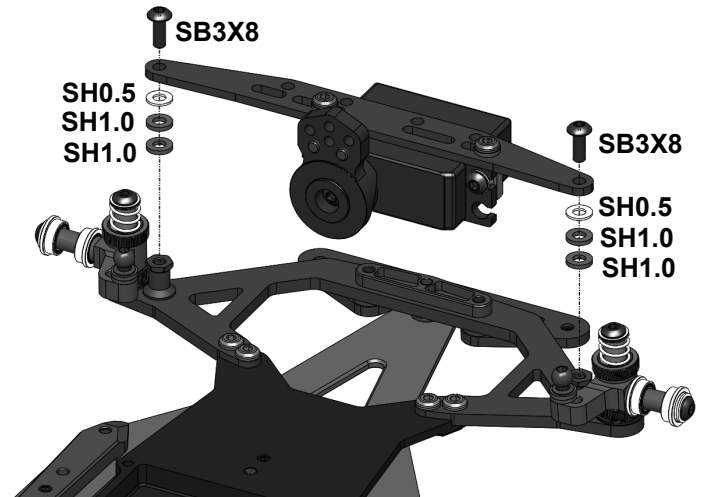

STEP 20

Install both steering links.

Left steering link

Right steering link

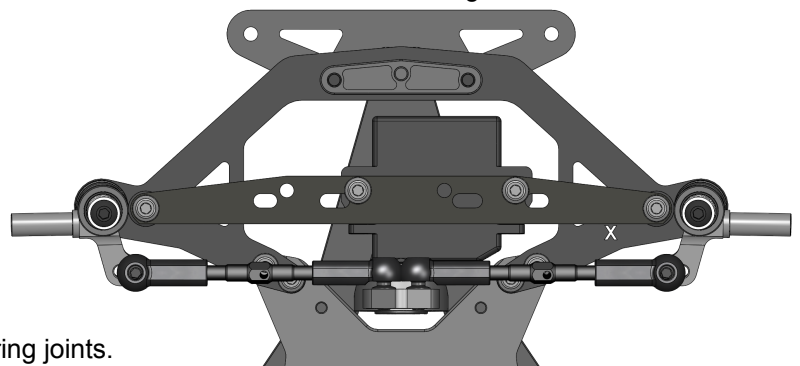

Note: P1213 4.0mm ball cups are used for the inner steering joints.

STEP 21

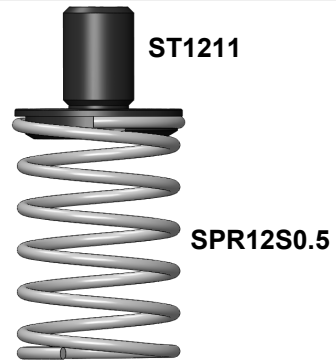
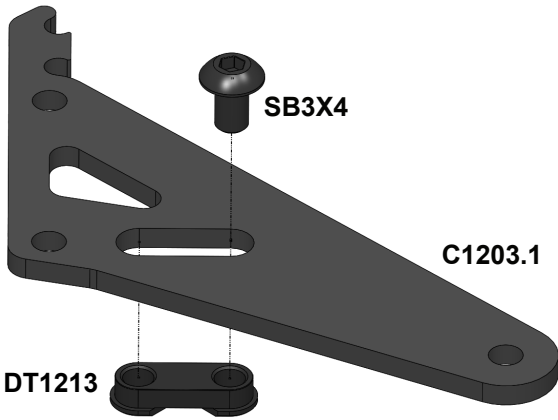

Snap the spring on the groove of **ST1211** retainer and rotate the spring to find the mutual angular position that provides a perfect alignment of the spring and retainer.

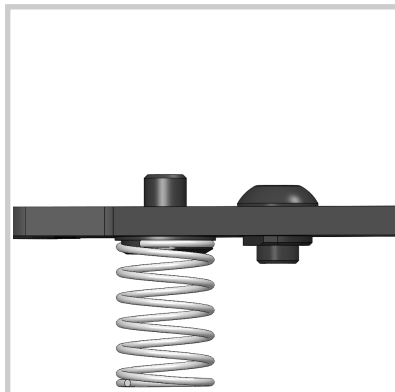
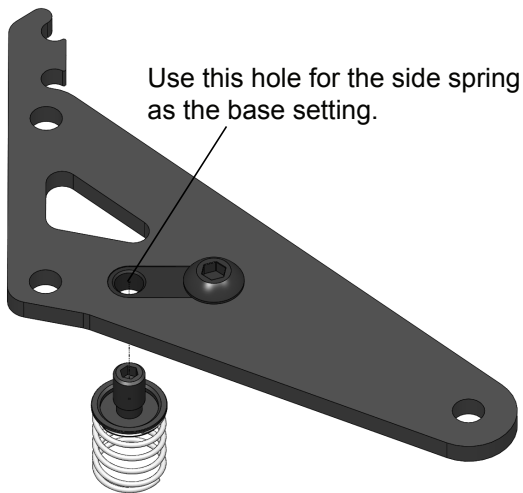

Initial position of the side spring. **ST1211** spring retainer should be screwed fully.

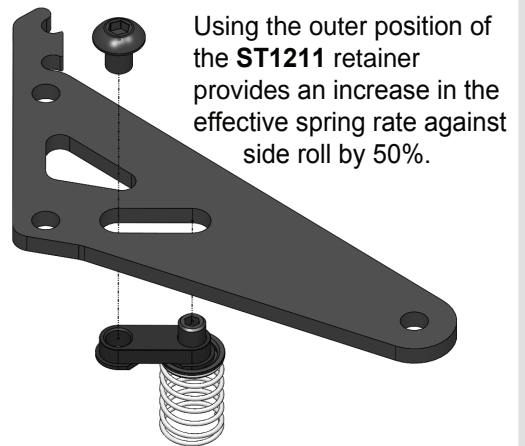

Unscrew **SB3X4**, rotate **DT1213** with installed **ST1211** and spring 180 deg and tighten **SB3X4** screw in new position.

STEP 22

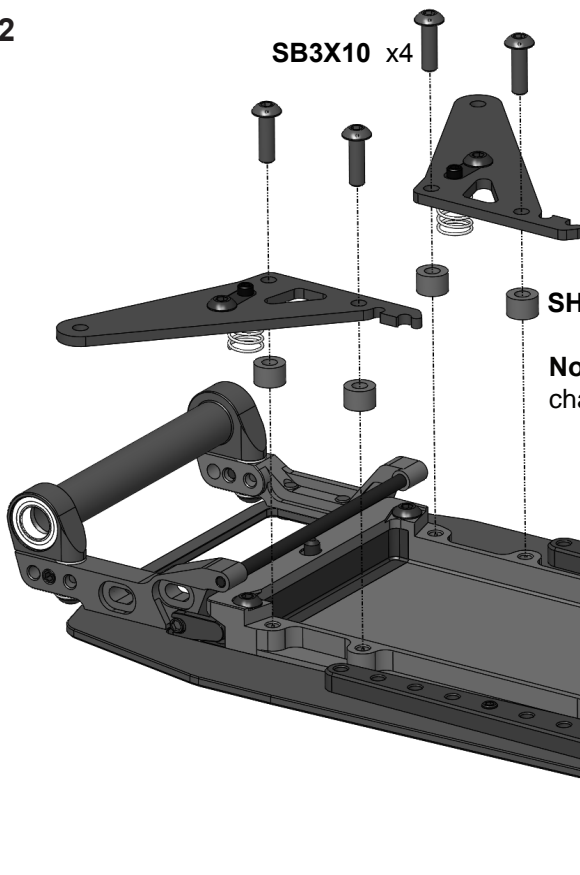

Assemble the left body holder in the same manner as the right body holder and install both body holders on the chassis.

SH4.0 (6x3x4mm spacer) x4

Note: Additional spacers can be used together with **SH4.0** to change the side springs operational range.

STEP 23

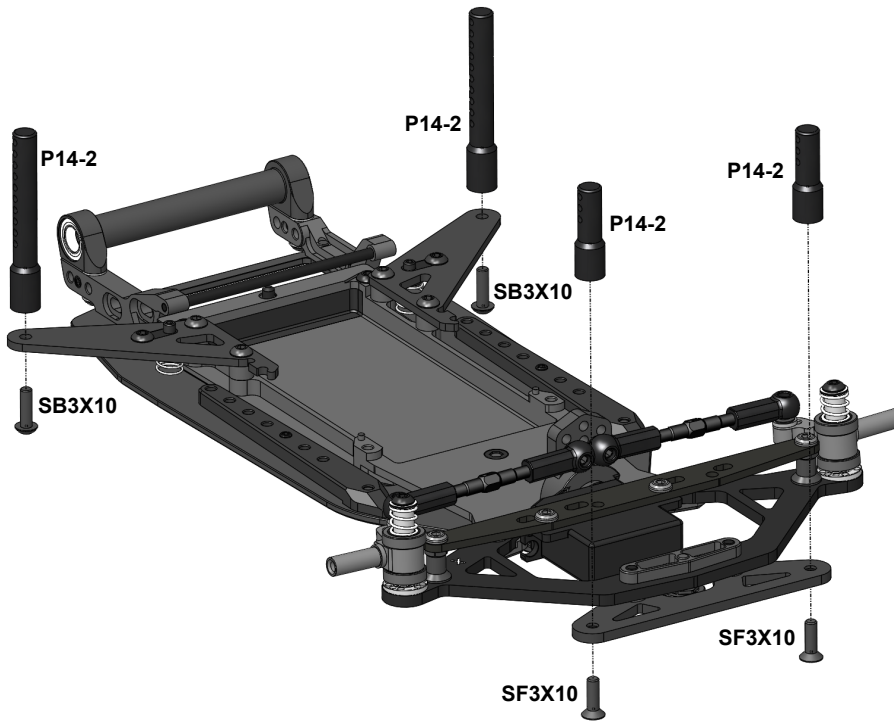

Note: Use thin double sided tape to secure P1215 foam bumper on C1204 bumper plate.

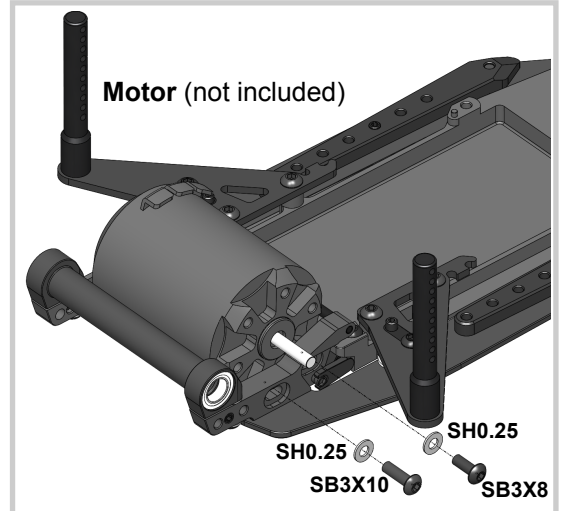
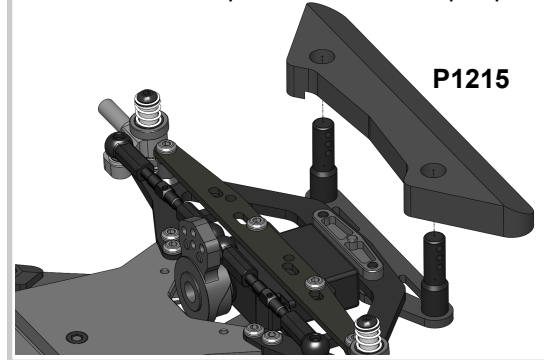

STEP 24

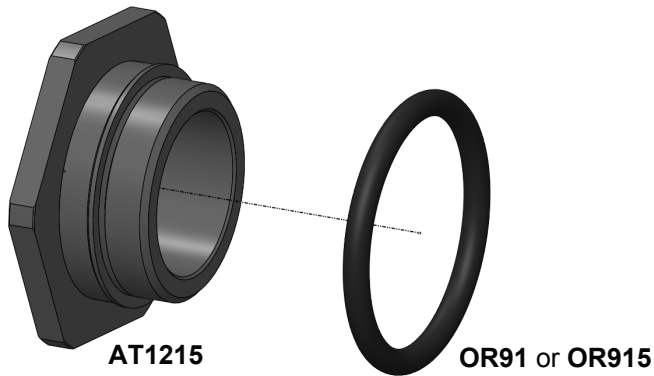

Note: Use OR91 9x1mm o-ring with the thick spur gears. Use OR915 9x1.5mm o-ring with the thinner spur gears (TC-style spur gears).



Spur gear (not included)

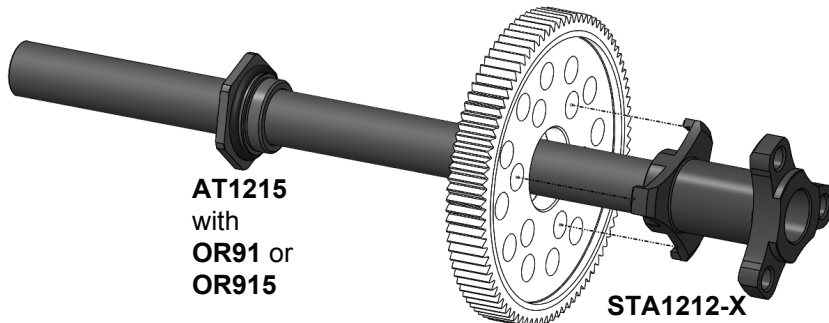

Note: Tighten AT1215 nut via 12mm wrench. Please don't overtighten AT1215 nut!

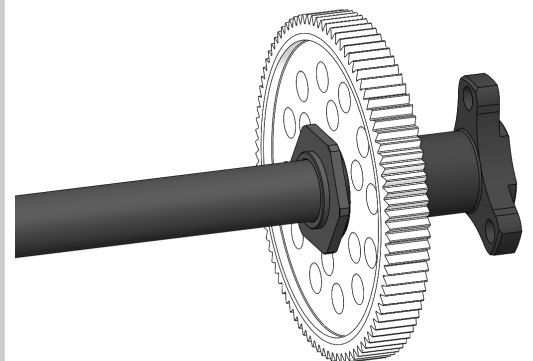

Note: The sum of the 64P spur+pinion teeth should be within 112-118 range for short wheel base and within 112-123 range for +1mm longer wheel base.

STEP 25

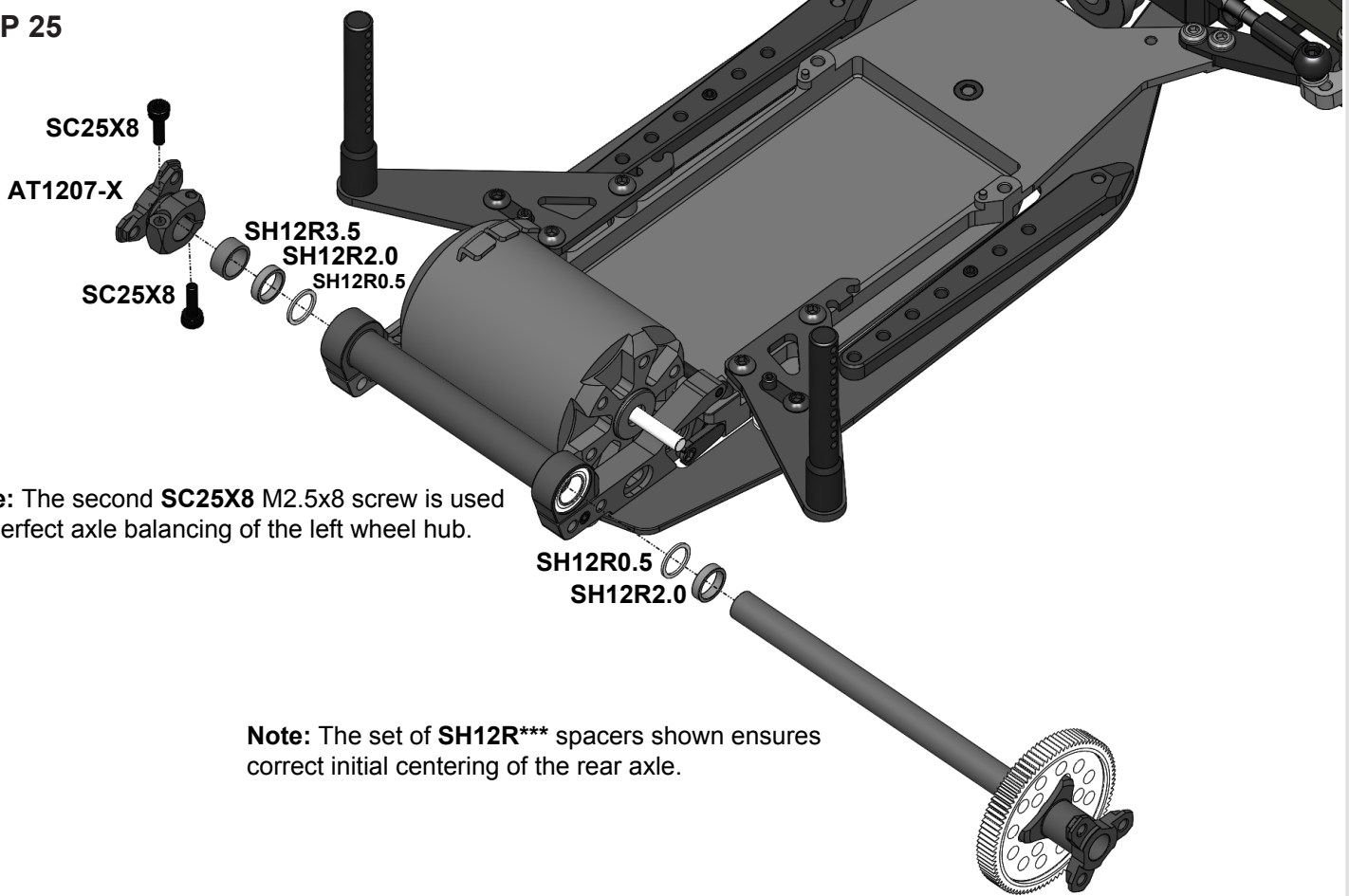

Note: The second **SC25X8** M2.5x8 screw is used for perfect axle balancing of the left wheel hub.

Note: The set of **SH12R***** spacers shown ensures correct initial centering of the rear axle.

Carbon Spool set **CS-1** (optional).

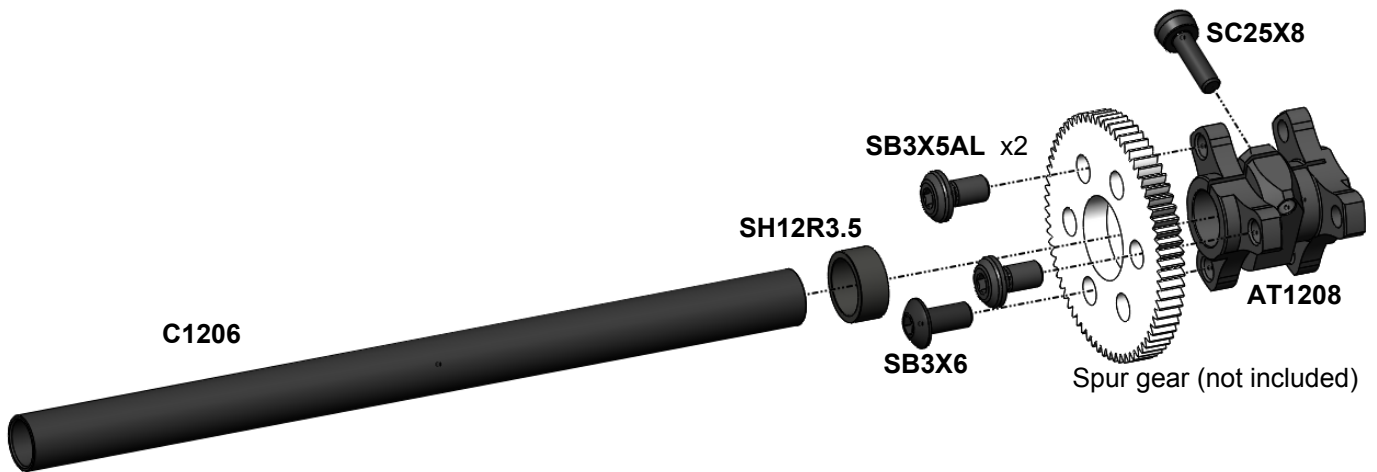

Note: Optional **ST1212** steel axle can be used instead of **C1206** carbon axle.

Note: Two **SB3X5AL** M3x5 alloy screw with one **SB3X6** M3x6 steel screw are used for perfect axial balancing of the right wheel hub.

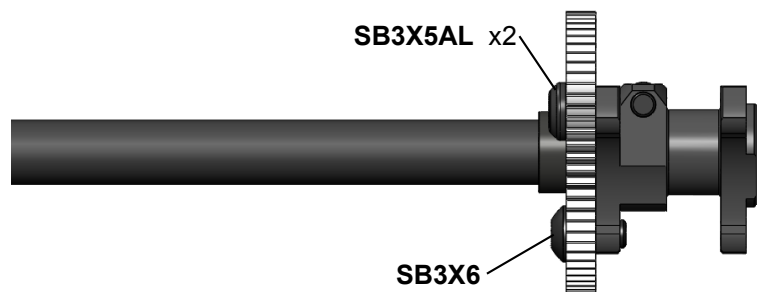

STEP 26

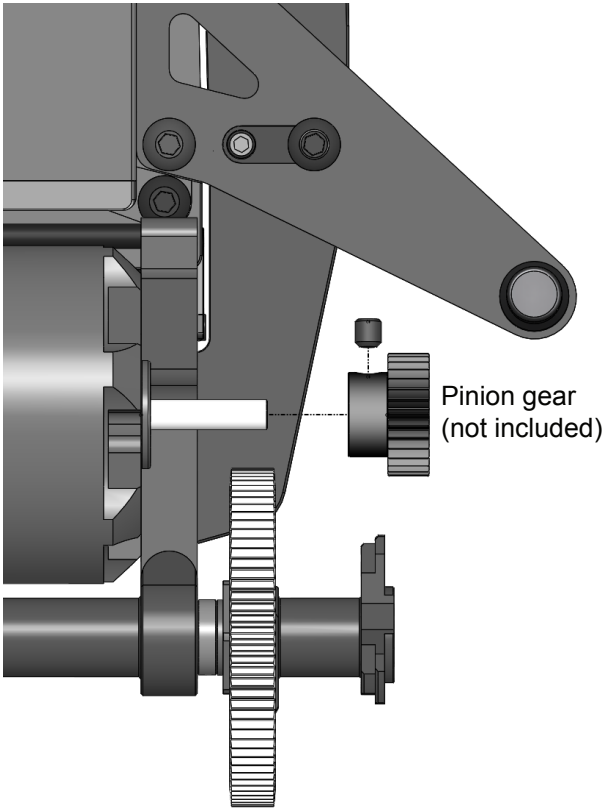

Note: The sum of the 64P spur+pinion teeth should be within 112-118 range for short wheel base and within 112-123 range for +1mm longer wheel base.

STEP 27

Note: Combination of SH12F0.5 spacers on both sides of the front wheel is used for the front width adjustment.

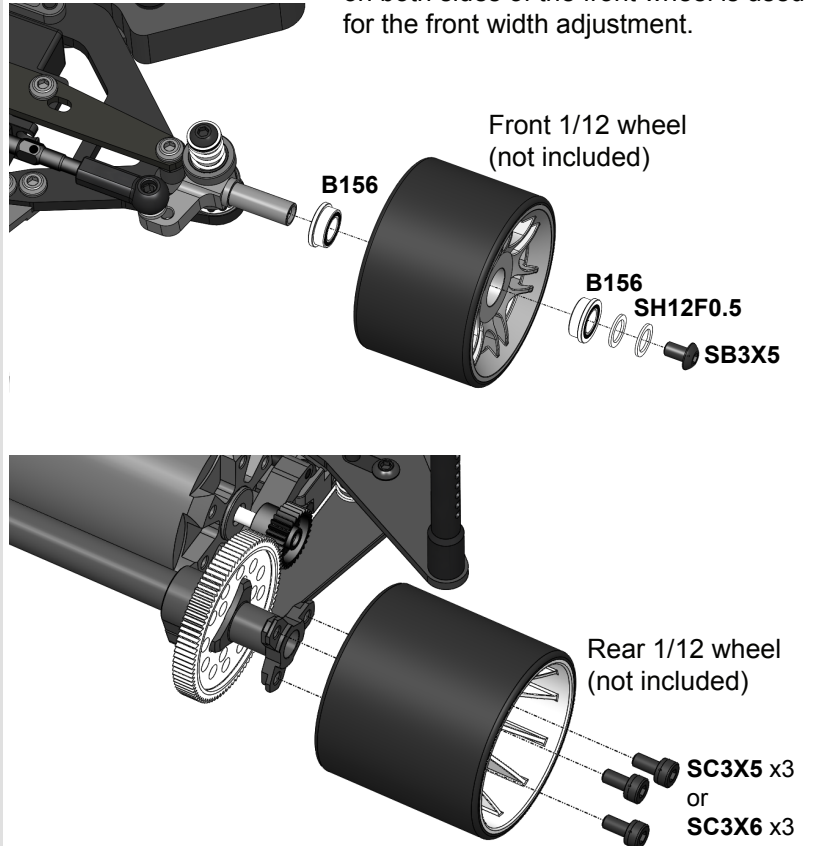

Note: Use SC3X5 or SC3X6 depending of the rear rims chosen. Some rims may need optional 3x8 mm screws (not included).

STEP 28

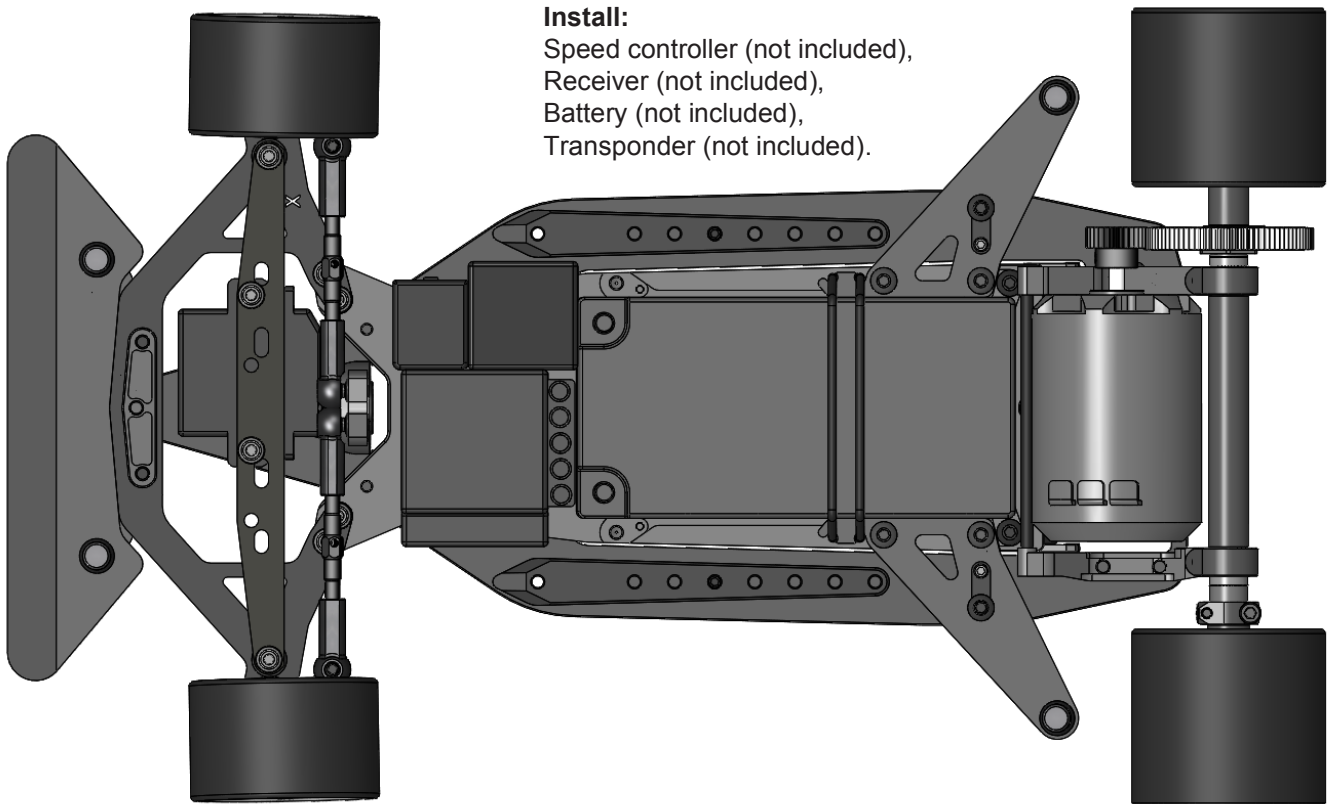

Install:

Speed controller (not included),
Receiver (not included),
Battery (not included),
Transponder (not included).

When using big tires, you will need to use shims under the C1205 to obtain the desired ride height. Placing shims under the steering block will not be sufficient to lower the ride height to proper height with larger tire sizes, so please use this additional method of adding shims under the C1205-X

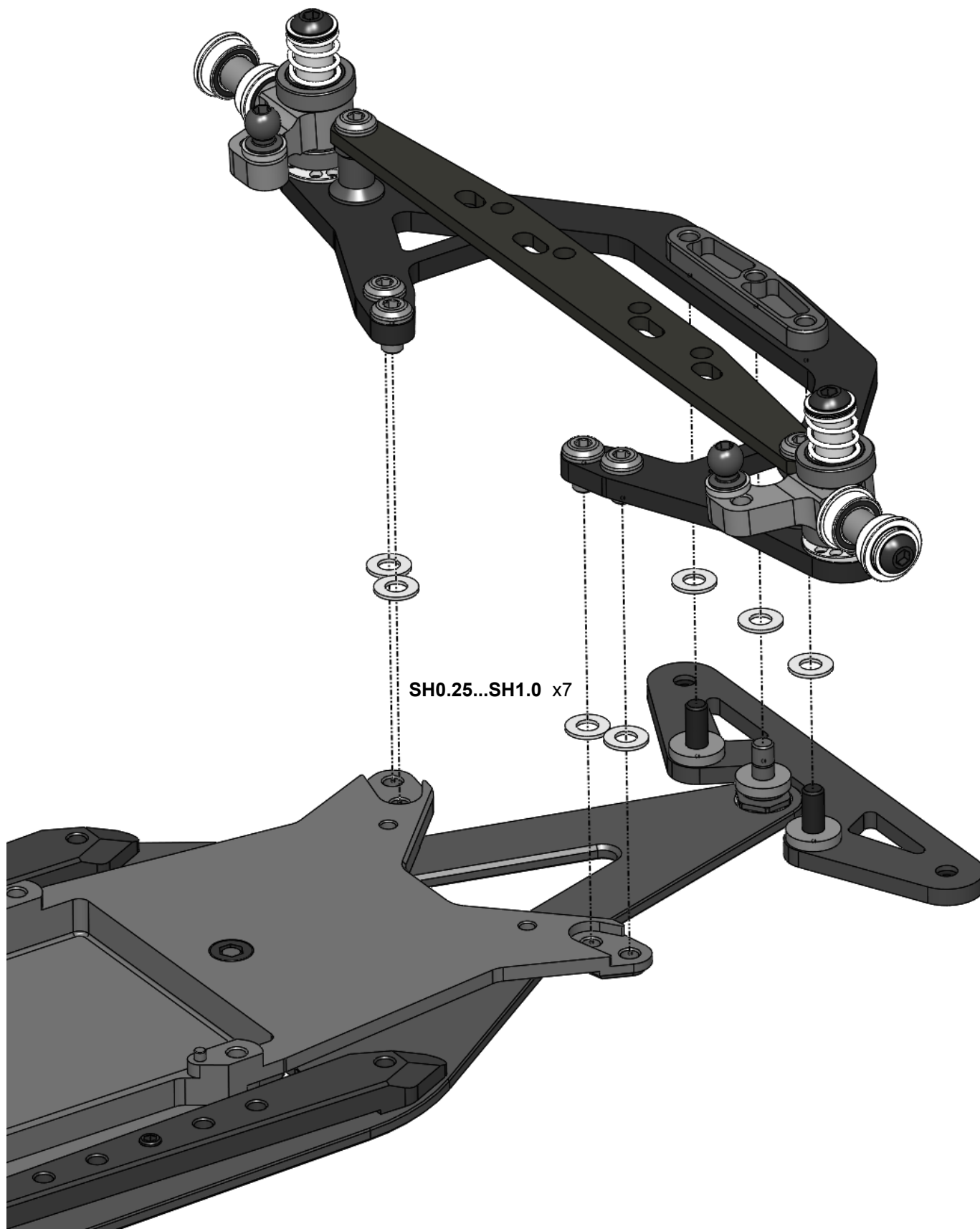

Setting of the Gap Under Damper (GUD).

Gap Under Damper - the **GUD** value indicates how far the bottom surface of the rear damper is above the chassis level.

The **GUD** value can be measured using the **DG1X** gauge when the fully equipped car is placed on the flat stand like on the picture.

When measuring the **GUD**, insert the **DG1X** gauge in the gap between the **ST1204** rear damper body and the stand.

The **GUD** is set via simultaneous and equal preload of two side springs **SPR12S0.5**. Rotate the left and the right spring retainers **ST1211** to the same rotation angle using 1,5 mm hex driver; turn clockwise to increase the rear spring preload and to increase the **GUD**; turn counterclockwise to decrease the rear spring preload and to decrease **GUD**.

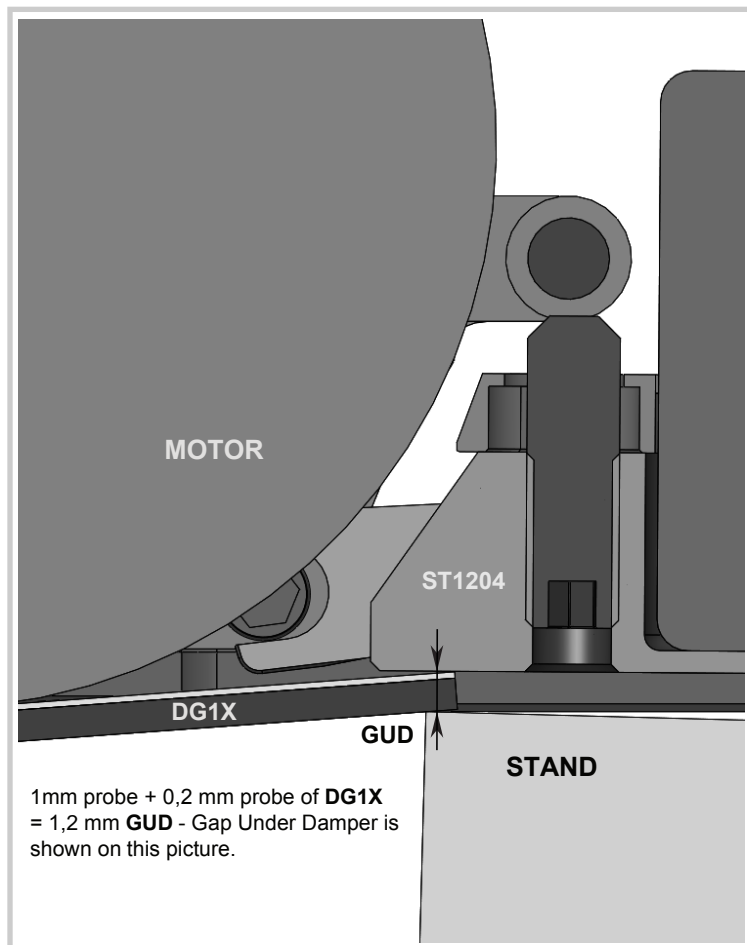
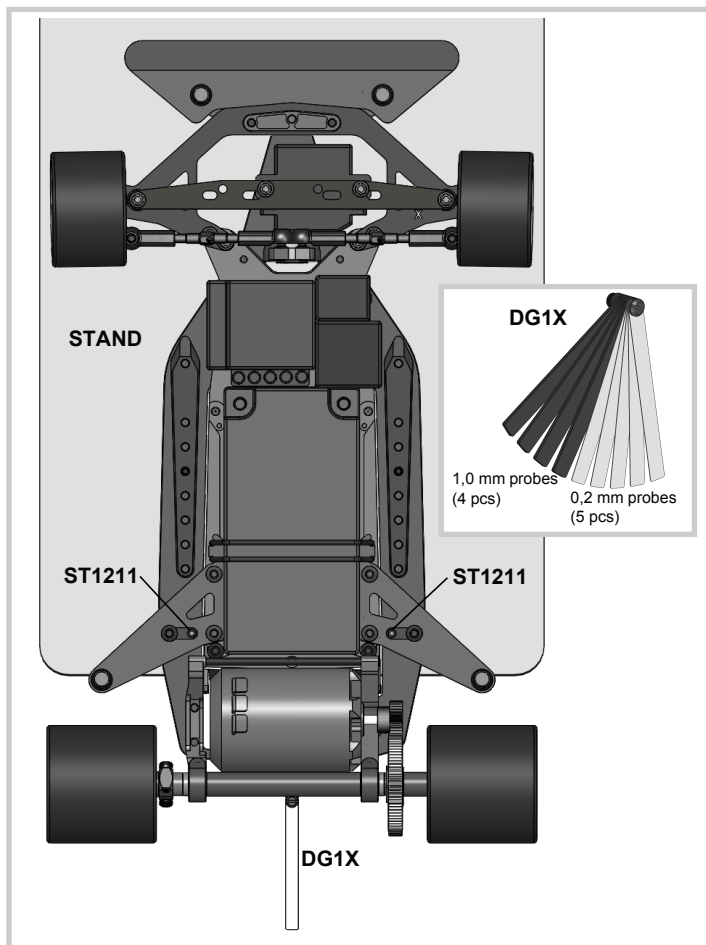

Setting of the Rear Downstop (RD).

Rear Downstop (**RD**) value in the A12WC car indicates how far the motor pod can drop below the bottom surface of the rear damper.

Adjusting of **SS3X10** set screw position - **Downstop Screw Depth (DSD)** is used for setting of the rear downstop **RD**.

DSD can be measured via calipers or via counting of the number of turns the screw is screwed into damper's case. Every turn of the thread is 0,5mm in depth. So for example, 4 full turns of **SS3X10** screw starting from position when the lower face of the screw coincides with the lower face of the damper corresponds to 2mm **DSD**.

$$\text{Equation for the Rear Downstop: } \mathbf{RD = 3.3 - DSD}$$

Enter **DSD** value into the A12WC editable setup sheet. The Rear Downstop value **RD** will be calculated automatically.

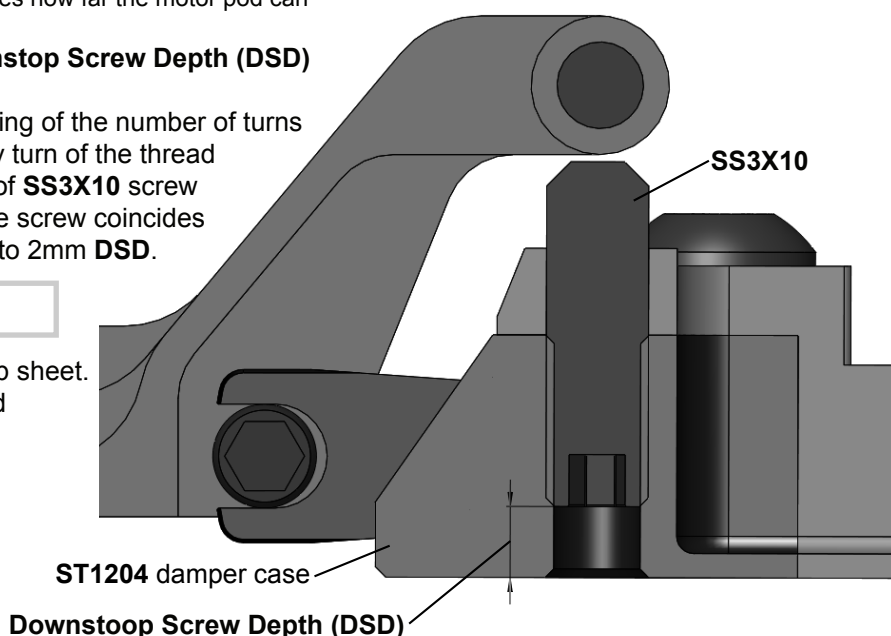

Optional roll centers sets.

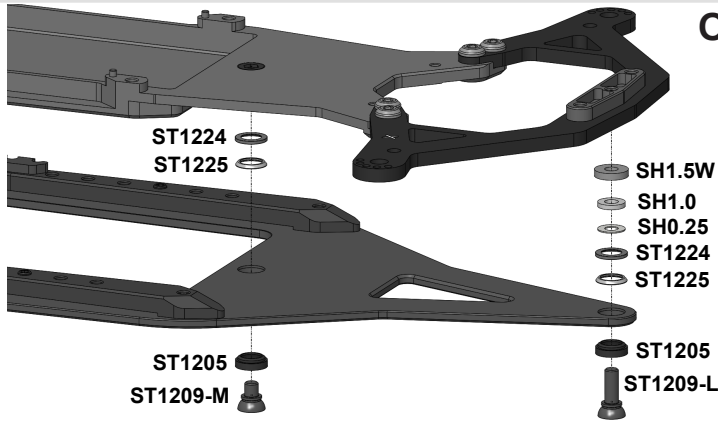

ELRC Set

ST1205	- 2 pcs
ST1209-M	- 1 pcs
ST1209-L	- 1 pcs
ST1224	- 2 pcs
ST1225	- 2 pcs

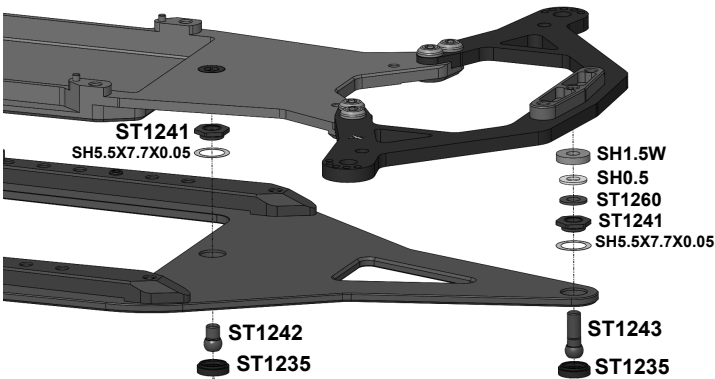
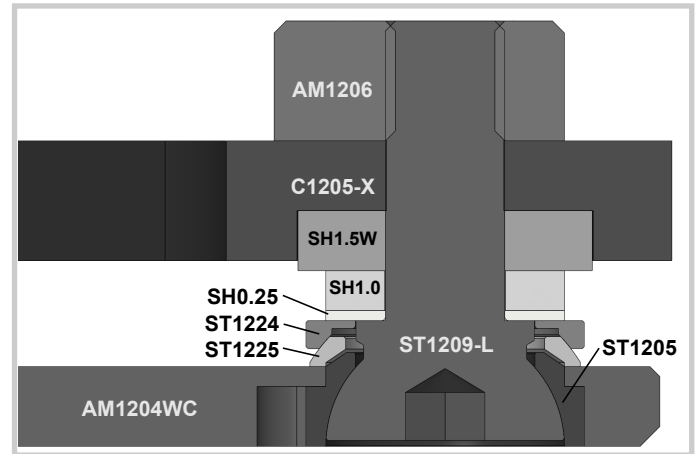
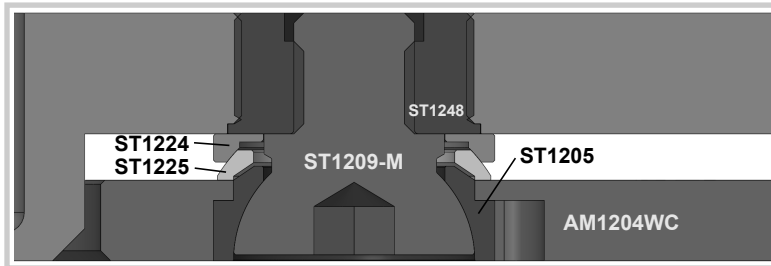

HRC Set

ST1235	- 2 pcs
ST1241	- 2 pcs
ST1242	- 1 pcs
ST1243	- 1 pcs
SH5.5X7.7X0.05	- 2 pcs

Try to install the joints without **SH5.5X7.7X0.05** shims first. Add these shims only if **ST1242** and **ST1243** do not pivot freely. Use **T03** tool when screwing **ST1241**.

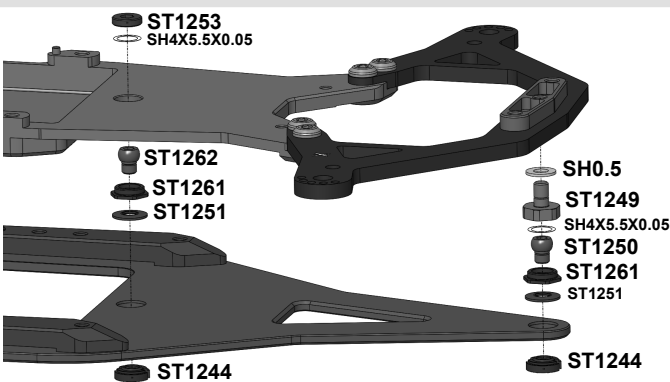
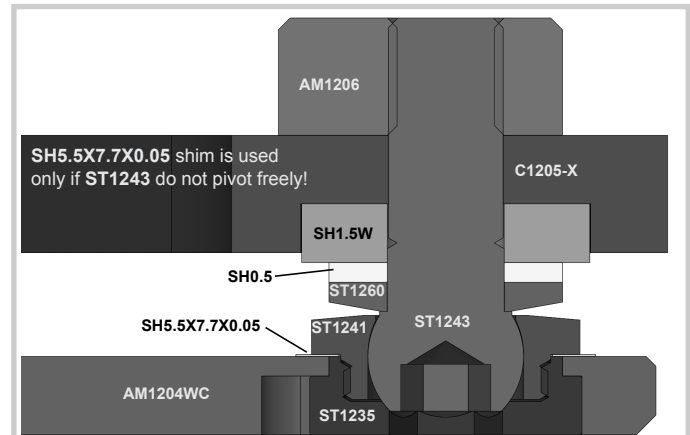
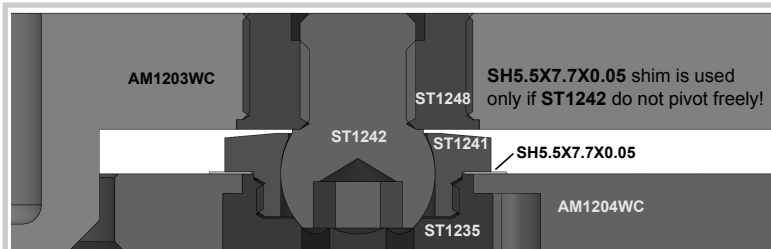

EHRC Set

ST1244	- 2 pcs
ST1249	- 1 pcs
ST1250	- 1 pcs
ST1251	- 2 pcs
ST1261	- 2 pcs
ST1262	- 1 pcs
ST1253	- 1 pcs
SH4X5.5X0.05	- 2 pcs

Try to install the joints without **SH4X5.5X0.05** shims first. Add these shims only if **ST1250** or **ST1262** do not pivot freely. Use **T03** tool when screwing **ST1261**. Use 1,5 or 2 mm hex driver when screwing **ST1250** and **ST1262**. Use the 1,5 mm Allen key in the recess of **ST1204-ST** to secure **ST1244** when tightening or unscrewing **ST1250** and **ST1262**. Use 2,5 mm hex driver when screwing **ST1253**.

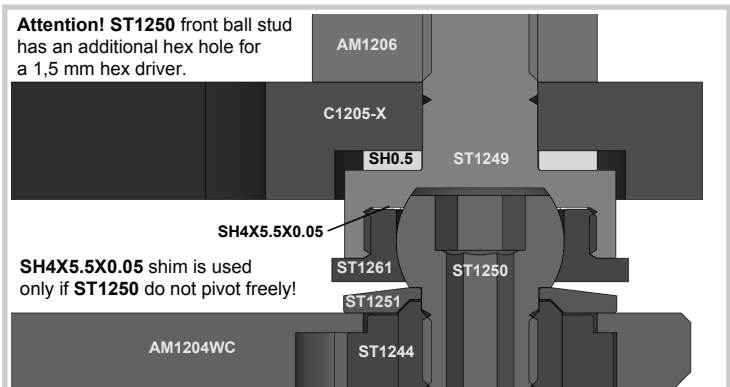
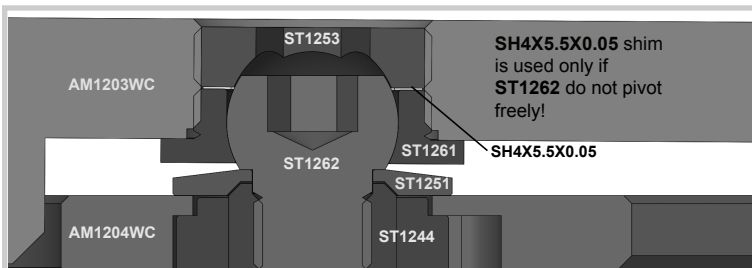

Attention! **ST1250** front ball stud has an additional hex hole for a 1,5 mm hex driver.

SH4X5.5X0.05 shim is used only if **ST1250** do not pivot freely!

NAME _____ DATE _____ TEMPERATURE AIR / TRACK °C / °C

COUNTRY _____ ASPHALT OUTDOOR INDOOR CARPET

RACE _____ TRACK CONDITION BUMPY FLAT TECHNICAL MIXED FAST

TRACK _____ TRACTION LOW MEDIUM HIGH

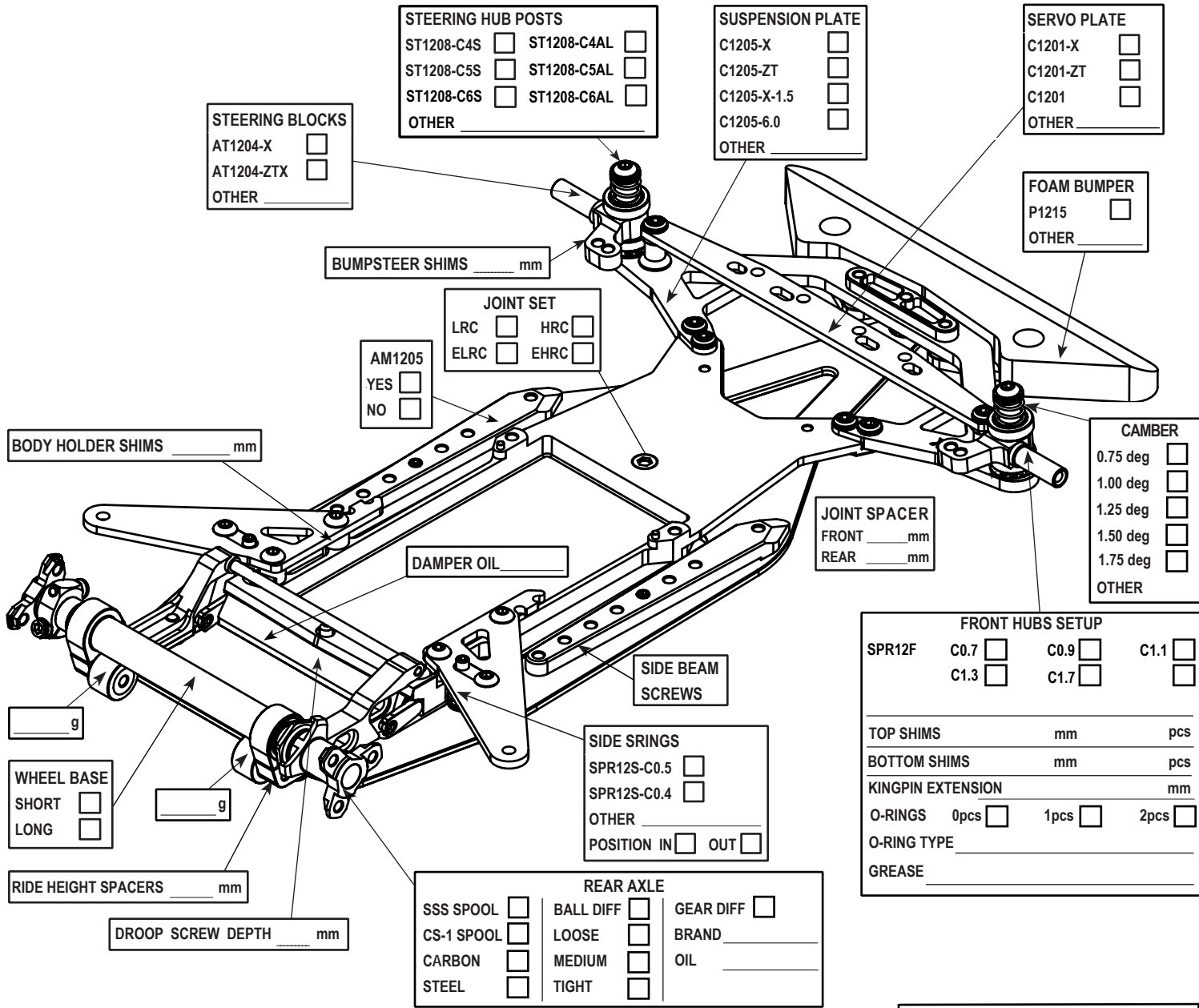

FRONT RIDE HEIGHT (FRH)	mm	FRONT DROOP (FD)	mm
REAR RIDE HEIGHT (RRH)	mm	REAR DOWNSTOP (RD)	mm
GAP UNDER DAMPER (GUD)	mm	TRACK WIDTH	
DROOP SCREW DEPTH (DSD)	mm	FRONT	mm
SPRING RETAINER HEIGHT (SRH)	mm	REAR	mm

BATTERY		SERVO	
BATTERY PLUGS	FRONT <input type="checkbox"/> BACK <input type="checkbox"/>	SERVOSAVER	
SERVO POSITION	LEFT <input type="checkbox"/> RIGHT <input type="checkbox"/>	SHIMS ON SERVOSAVER	
ESC POSITION	LEFT <input type="checkbox"/> RIGHT <input type="checkbox"/>	TOE OUT	
		STEER. TRAVEL IN ° OUT °	

TIRES	FRONT	REAR	FRONT		REAR	
BRAND						
TYPE						
DIAMETER	mm	mm				
ADDITIVE			TIME	min	TIME	min

MOTOR	TOTAL WEIGHT	g
SPUR PINION ROLLOUT	F/R WEIGHT DISTRIBUTION	
ESC	RECEIVER	
ESC SETTING	RADIO	
BODY	REAR BODY HEIGHT (SIDE DAMS)	mm
BEST LAP TIME	QUALIF. / FINAL POSITION	/

COMMENTS:

Spare parts

Parts #	Description	Parts #	Description
AM1202.1	Motor Mount	SPR12S0.5	Side Spring C0.5
AM1203WC	Battery Plate	SPR05	Body Clip
AM1204WC	Chassis Plate	B156	3/16x5/16x1/8 Flanged Bearing
AM1205.1	Side Beam	B168	1/4x3/8x1/8 Flanged Bearing
AM1206	Front Nut	SH12S-0.2	Spring Shim 0.2mm
AM1207.1	Left Bulkhead	SH12F0.5	Front Axle Spacer 0.5mm
AT1201	Steering Block Nut	SH12R0.5	Rear Axle Spacer 0.5mm
AT1202	Servo Post	SH1.5W	7.4x3x1.5mm Spacer
AT1203	Rear Beam	SH12R2.0	Rear Axle Spacer 2.0mm
AT1204-X	Steering Block	SH12R3.5	Rear Axle Spacer 3.5mm
AT1206	Servo Plate Post	SH5.5X7.7X0.05	5.5X7.7X0.05 Shim
AT1207-X	Left Hub	SH0.1	6x8x0.1mm Shim
AT1215	Spur Nut	SH0.25	6x3x0.25mm Spacer
AT25-2	Turnbuckle 39mm x 2	SH0.5	6x3x0.5mm Spacer (Silver)
DT1202	Steering Washer	SH1.0	6x3x1.0mm Spacer (Gray)
ST1201	3mm Ball Stud	SH4.0	6x3x4.0mm Spacer
ST1202	Damper Rotor	OR155SI	1.5x5mm O-Ring Silicone
ST1203.1	Downstop Rod	OR230	2x30mm O-Ring
ST1204	Damper Case	OR15	1x5mm O-Ring
ST1205	Ball Cup	OR153V	1.5x3mm O-Ring Viton
ST1207	Steering BlockTube	OR91	9x1mm O-Ring
ST1208-C4AL	Steering Block Post	OR915	9x1.5mm O-Ring
ST112	Screw	SC25X8	M2.5x8 Cap Head Screw
ST1248	Battery Plate Nut	SS3X5	M3x5 Set Screw
ST1254	LRC Seat	SS3X10	M3x10 Set Screw
ST1255	LRC Nut	SC3X5	M3x5 Cap Head Screw
ST1256	LRC Rear Ball	SC3X6	M3x6 Cap Head Screw
ST1257	LRC Front Ball	SB3X4	M3x4 Button Head Screw
ST1260	Tapered Spacer	SB3X5	M3x5 Button Head Screw
ST1211	Spring Retainer	SB3X6	M3x6 Button Head Screw
ST24-4.0	4.0mm Ball Stud	SB3X8	M3x8 Button Head Screw
ST24	4.8x6mm Ball Stud	SB3X10	M3x10 Button Head Screw
STA1212-X	Composite Axle	SB3X12	M3x12 Button Head Screw
P1215	Foam Bumper	SF3X6	M3x6 Flat Head Screw
P13-4	Ball Cup	SF3X10	M3x10 Flat Head Screw
P1213	Ball Cup 4.0 mm	SB3X5AL	M3x5 Alloy Screw
DT1213	Side Spring Holder	STS-A12	A12 Stickers Sheet
P14-2	Body post	SIO100K	100k Silicone Oil
C1201-X	Servo Plate	DG1X	FG1X Gauge
C1203.1	Body Holder	T03	6/7 mm Wrench
C1204	Bumper Plate		
C1205-X	Suspension Plate		
SPR12F-C1.1	Front Spring Soft		

Parts #	Description	Parts #	Description
RHG 4.2X	Ride Height Gauge	C1205-6.0	Suspension Plate
CS-1	Carbon Spool Set	C1201-6.0	Servo Plate
AT1204-ZTL	Steering Block Zero Trail	C1201	Servo Plate
ST1208-C5AL	Steering Hub Post 5 Deg	C1205-ZT	Suspension Plate Zero Trail
ST1208-C6AL	Steering Hub Post 6 Deg	C1205-X-1.5	Suspension Plate
ST1208-C2AL	Steering Hub Post 2 Deg	C1201-ZT	Servo Plate Zero Trail
ST1208-C6	Steering Hub Post 6 Deg	AM1204WC	Chassis Plate
ST1216	Balance Weight 5 g	ST1208-C2ST	Steering Hub Post 2 Deg
ST1212	Spring Steel Axle	ST1208-C4ST	Steering Hub Post 2Deg
C1206	Carbon Axle	ST1208-C5ST	Steering Hub Post 5 Deg
OR155PU	1.5x3mm O-Ring PU	ST1208-C6ST	Steering Hub Post 6 Deg
SH12R5.5	Rear Axle Spacer 5.5mm	SPR12S-C0.4	Side Spring Long C0.4
SC25X7AL	2.5x7 Cap Head Screw Alloy	SPR12S-C0.5	Side Spring Long C0.5
AT1208	Right Hub	SPR12S-C0.6	Side Spring Long C0.6
SPR12F-C1.7	Front Spring C1.7	ELRC	Extra Low Roll Center Set
SPR12F-C1.3	Front Spring C1.3	HRC	High Roll Center Set
SPR12F-C0.9	Front Spring C0.9	EHRC	Extra High Roll Center Set
SPR12F-C0.7	Front Spring C0.7	SH12F0.1	Front Axle Spacer 0.1mm

