

Driver: _____ Track: _____ Event: _____
 Date: _____ Qualifying: _____ Final: _____ Best Lap: _____

TRACK TYPE

Grip Level High Medium Low
 Type Tight Open Mixed
 Condition Flat Bumpy Mixed
 Surface Tarmac (Asphalt) Carpet
 Track Temp _____ °C
 Weather _____

Notes:

TYRES

Tyres _____
 Cleaner _____
 Additive _____
 Additive Time Front: _____ mins Rear: _____ mins
 Heating Time Front: _____ mins Rear: _____ mins
 Heating Temp Front: _____ °C Rear: _____ °C

Notes:

FRONT

KEY: CF = Carbon Fibre, AL = Aluminium, P = Plastic, F = Front, R = Rear
 H = High, L = Low, Y = Yes, N = No, V = Vertical, H = Horizontal

Ride Height _____ mm
 Camber _____ deg
 Droop _____ mm
 Castor _____ deg
 Toe _____ deg
 Anti Roll Bar 1.1 1.2 1.3 1.4
 Upper Link Mount 0 dot 1 dot
 Spool Height H L
 Diff Oil (if applicable) _____ cSt
 Servo Horn Height _____ mm Saver
 Steering Travel _____ in _____ out

Notes:

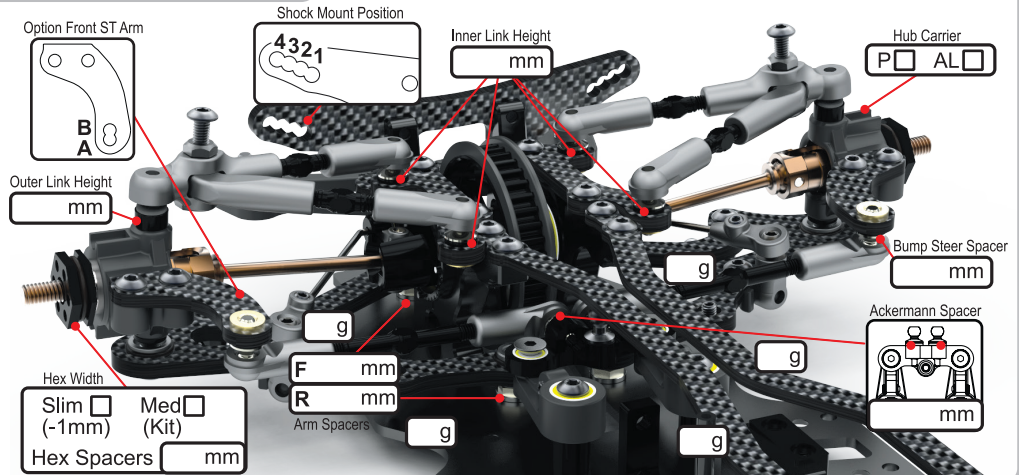

REAR

KEY: CF = Carbon Fibre, AL = Aluminium, P = Plastic, F = Front, R = Rear
 H = High, L = Low, Y = Yes, N = No, V = Vertical, H = Horizontal

Ride Height _____ mm
 Camber _____ deg
 Droop _____ mm
 Castor _____ deg
 Toe _____ deg
 Anti Roll Bar 1.1 1.2 1.3 1.4
 Upper Link Mount 0 dot 1 dot
 Diff Height H L
 Diff Oil _____ cSt

Notes:

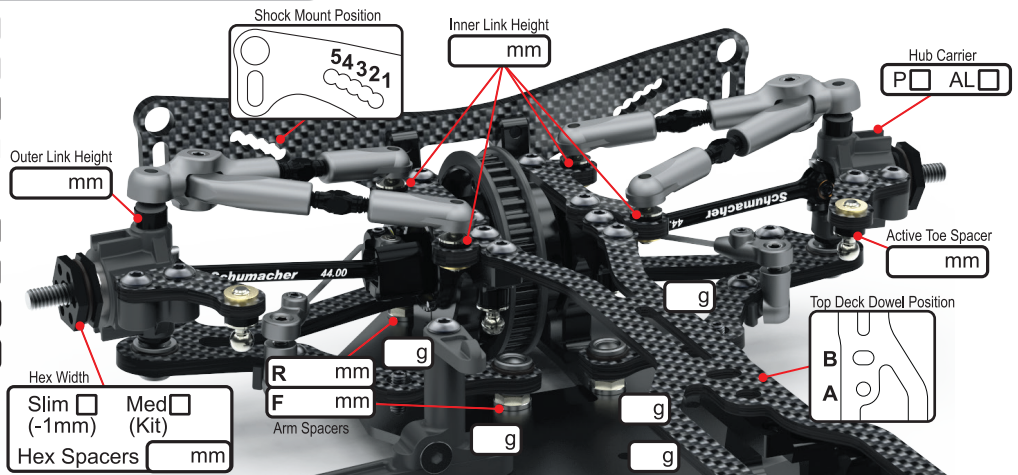

BODYSHELL

Body _____
 Wing _____
 Wing Height _____ mm
 Front Height _____ mm
 Body Stopper Y N
 Stopper Height _____ mm
 Body Weight _____ g
 Rear Posts V H
 Body Offset Fwrd _____ mm
 Wing Offset Rwrdr _____ mm

Notes:

CHASSIS

Chassis AL CF
 Top Deck 2mm Kit
 1.6mm
 2 piece
 T Brace Y N
 Motor Mount Screws
 1 2 3 4
 Rear Front
 Total Weight _____ g
 Mass Damper
 F _____ cSt
 R _____ cSt

Notes:

ELECTRONICS

E.S.C. _____
 Servo _____
 RX _____
 LiPo _____
 Motor _____
 Rotor Dia. _____ mm
 Timing _____ deg
 Gear Pitch 48 64
 Pinion _____ t
 Spur _____ t
 Ratio _____

SHOCKS

KEY: x = Stroke, e = external
 V = Vented (Drilled), S = Sealed

	FRONT	REAR
Cap Type	<input type="checkbox"/> V <input type="checkbox"/> S	<input type="checkbox"/> V <input type="checkbox"/> S
Body	<input type="checkbox"/> Kit <input type="checkbox"/> Kashima Coated	
Oil	_____ cSt	_____ cSt
Piston	_____	_____
Spring	_____	_____
Length (x)	_____ mm	_____ mm
Rebound	_____ mm	_____ mm
Limiters (e)	_____ mm	_____ mm

Notes: